

ppbRAE

Parts per Billion VOC Monitor

PGM-7240

OPERATION AND MAINTENANCE

MANUAL

(Document No.: 025-4001)

April 2003, Rev C2



**RAE SYSTEMS INC.
1339 Moffett Park Drive
Sunnyvale, CA 94089**



ATTENTION!

For European Applications

A. CE 0575  II 1G

DEMKO 03 ATEX 0204759X

Eex ia IIC T4

B. Recharge batteries only in non-hazardous locations.

C. Do not connect external cable to serial interface jack in hazardous locations.

D. Use RAE Systems Adapter P/N 500-0072 for connection to communication port and charging jack only in a non-hazardous area.

Table of Contents

Chapter 1 General Information	1
1.1 Specifications	3
Chapter 2 Operation of ppbRAE	7
2.1 Physical Description	8
2.2 Keys and Display	9
2.3 Power On/Off	10
2.4 Operation	11
2.4.1 Survey Mode	12
2.4.2 Hygiene Mode	18
2.5 Alarm Signals	20
2.6 Alarm Limits and Calibration	22
2.7 Integrated Sampling Pump	23
2.8 Back Light	24
2.9 Datalogging	25
Chapter 3 Operation of Accessories	27
3.1 Standard Kit and Accessories	28
3.2 Optional Accessories	31
Chapter 4 Programming of ppbRAE	33
4.1 Programming Mode	34
4.2 Keys for Programming Mode	35
4.3 Entering into Programming Mode	36
4.4 Calibrate and Select Gas	37
4.4.1 Zero Calibration	39
4.4.2 Span Calibration	40
4.4.3 Selecting Cal Memory	42
4.4.4 Changing the Span Value	43
4.4.5 Modifying the Cal Memory	44
4.4.6 Changing the Correction Factor	45

4.5	Changing Alarm Limits	46
4.5.1	Changing Low Alarm Limit	48
4.5.2	Changing the STEL Limit	49
4.5.3	Changing the TWA Limit	50
4.6	Viewing or Changing the Datalog	51
4.6.1	Viewing Data (Datalog)	52
4.6.2	Clearing Data	54
4.6.3	Changing the Data Period	55
4.6.4	Changing the Average Type	56
4.7	Changing Monitor Setup	57
4.7.1	Changing Operation Mode	58
4.7.2	Changing Site ID	59
4.7.3	Changing User ID	60
4.7.4	Changing Alarm Mode	61
4.7.5	Changing the User Mode	62
4.7.6	Changing the Date	63
4.7.7	Changing the Time	64
4.7.8	Changing the Lamp	65
4.7.9	Changing the Units	66
4.7.10	Changing the Output	67
4.7.11	Changing the Pump Speed	68
4.7.12	Changing the DAC Range	69
4.8	Exit Programming Mode	70
Chapter 5 Computer Interface		71
5.1	Install ProRAE-Suite Software	72
5.2	Connecting ppbRAE to the PC	74
5.3	Starting ProRAE-Suite Software	75
5.4	Setup Communication Port	77
5.5	Processing the Configuration Data	78

5.5.1	Editing the Configuration Data	79
5.5.2	Send Configuration to the ppbRAE	87
5.5.3	Saving Configuration Data	88
5.5.4	Configuring all Settings	89
5.6	Processing the Logged Data	90
5.6.1	Receiving Data	91
5.6.2	View Logged Data in Text Mode	92
5.6.3	View STEL/TWA/AVG Value	93
5.6.4	View Summary Information	94
5.6.5	View Logged Data in Graph Mode	95
5.6.6	Export Displayed Data to a Text File	98
5.6.7	Exporting Graph to a File	99
5.6.8	Printing the Logged Data	100
5.6.9	Installing Datalog Capability	101
5.7	Upgrading the Firmware	103
Chapter 6 Theory of Operation		105
Chapter 7 Maintenance		109
7.1	Battery Charging and Replacement	110
7.2	PID Sensor & Lamp Cleaning/Replacement	112
7.3	Sampling Pump	114
7.4	Turning on the UV Lamp	116
Chapter 8 Troubleshooting		119
8.1	Special Diagnostic Mode	120
8.2	Troubleshooting Table	127
Appendix A Quick Reference Guide		131
Appendix B Expendable & Replacement Part List		132

WARNING !

- Do NOT proceed before reading -

This manual must be carefully read by all individuals who have or will have the responsibility for using, maintaining or servicing this product.

The product will perform as designed only if it is used, maintained, and serviced in accordance with the manufacturer's instructions.

CAUTION!!!

To reduce the risk of electric shock, turn power off before removing the monitor cover. Disconnect the battery before removing the sensor module for service. Never operate the monitor while the cover is removed. Remove the monitor cover and sensor modules only in areas known to be non-hazardous.

The model PGM-7240 equipment is classified as intrinsically safety for use in class I, division 1, groups A, B, C, D, or non-hazardous locations only.

Special Note

When the ppbRAE Monitor is turned on in ambient air, it may read a few hundred ppb depending on how much ionizable gases are trapped inside the detector chamber or in the ambient air. The reading should stabilize in a few minutes after the residual vapor in the detector chamber is cleared.

The battery of the ppbRAE monitor will discharge slowly even if it is turned off. If the monitor has not been charged for 5-7 days, the battery voltage will be low. Therefore, it is good practice to always charge the monitor before using it. It is also recommended to fully charge the monitor FOR AT LEAST 10 HOURS before first use. See Section 7 for more information on battery charging and replacement.

STATIC HAZARD:

Clean only with damp cloth.

**DANGER RISQUE D'ORIGINE
ELECTROSTATIQUE:**

Nettoyer uniquement avec un chiffon humide.

CAUTION:

For safety reasons this equipment must be operated and serviced by qualified personnel only. Read and understand instruction manual completely before operating or servicing.

ATTENTION:

Pour des raisons de sécurité, cet équipement doit être utilisé, entretenu et réparé uniquement par un personnel qualifié. Étudier le manuel d'instructions en entier avant d'utiliser, d'entretenir ou de réparer l'équipement.

WARNING:

Use only RAE Systems battery packs, part nos. 012-3050, 012-3051 or 012-3052. This instrument has not been tested in an explosive gas/air atmosphere having an oxygen concentration greater than 21%. Substitution of components may impair intrinsic safety. Recharge batteries only in non-hazardous locations.

AVERTISSEMENT:

Utiliser seulement l'ensemble de batterie RAE Systems, la référence 012-3050, 012-3051 au 012-3052. Cet instrument n'a pas été essayé dans une atmosphère de gaz/air ayant une concentration d'oxygène plus élevée que 21%. La substitution de composants peut compromettre La sécurité intrinsèque. Ne charger Les batteries que dans L'emplacements désignés non dangereuse.

WARNING:

The calibration of all newly purchased RAE Systems instruments should be tested by exposing the sensor(s) to known concentration calibration gas before the instrument is used or put into service. For maximum safety, the accuracy of the ppbRAE should be checked by exposing the sensor(s) to known concentration calibration gas before each day's use.

AVERTISSEMENT:

La calibration de toute instruments de RAE Systems doivent être testé en exposant l'instrument a une concentration de gaz connue par une procédure dietalonnage avant de mettre en service l'instrument pour la première fois. Pour une securite maximale, la sensibilité du ppbRAE doit être verifier en exposant l'instrument a une concentration de gaz connue par une procédure dietalonnage avant chaque utilisation journalière.

1 General Information

The ppbRAE parts per billion (ppb) Volatile Organic Compound (VOC) Monitor (Model PGM-7240) is an extremely sensitive Photo-ionization Detector (PID) for real-time monitoring of volatile organic compounds (VOCs) at ppb levels. With its highly compact design, it is used as a broadband VOC gas monitor and datalogger for work in hazardous environments. The new RAE patented PID sensor has an increased sensitivity down to a few ppb, with reduced humidity interference, improved linearity, and an easily accessible lamp and sensor. Features are:

Lightweight and Compact

Compact and light weight (19.5 oz. with battery pack) in a durable, rugged design.

Strong, built-in sample draw pump with stall feature preventing liquid from flowing into the monitor.

Dependable and Accurate

Snap-in, field replaceable NMH rechargeable battery with smart battery charging.

Up to 10 hours of continuous monitoring with rechargeable battery pack.

Alkaline battery holder supplied.

Automotive charger available.

Continuously monitors VOCs at ppb levels.

Selectable cancel and show background of VOCs.

102 built-in correction factors from a RAE list of 250+ chemicals.

Protective rubber boot included.

User Friendly

Large keys operable with or without gloves.

Large easy to read display with back light.

Alarm activated.

Darkness or manually activated.

Preset alarm thresholds for STEL, TWA, low and high level peak values. Audio buzzer and flashing LED display are activated when the limits are exceeded.

User selectable hygiene and survey modes.

Protected from EMI and RMI.

Datalogging Capabilities

15,000 point datalogging storage capacity for data download to Personal Computer (PC).

Specifications

The ppbRAE consists of a PID with associated microcomputer and electronic circuit. The unit is housed in a rugged ABS + PC case with a backlight 1 line by 8 character dot matrix LCD and 3 keys to provide easy user interface.

GENERAL INFORMATION

Table 1-1. PpbRAE General Specifications

Size	8.2"L x 3.0"W x 2.0"H or 21.8 cm L x 7.62 cm W x 5.08 cm H									
Weight	19.5 oz with battery pack									
Detector	Photo-ionization sensor with standard 10.6 eV or optional 9.8 eV UV lamp.									
Battery	Rechargeable, compartmentalized, field replaceable Nickel Metal Hydride battery pack.									
Battery Charging	Up to 10 hours quick charge through the built-in smart charger.									
Operating Hours	10 continuous hours									
Display	Large LCD display, manual, auto back light, and alarm activated.									
Range, Resolution, & Response Time (t90):	<p>Isobutylene (calibration gas)</p> <table style="width: 100%; border: none;"> <tr> <td style="width: 33%;">0-9999 ppb</td> <td style="width: 33%;">1 ppb</td> <td style="width: 33%; text-align: right;"><5 sec</td> </tr> <tr> <td>10.0-99.9 ppm</td> <td>0.1 ppm</td> <td style="text-align: right;"><5 sec</td> </tr> <tr> <td>100-199 ppm</td> <td>1 ppm</td> <td style="text-align: right;"><5 sec</td> </tr> </table> <p>(Note: When using a 9.8 eV lamp, the reading may fluctuate. For more stable, accurate results use a 10.6 eV lamp.)</p>	0-9999 ppb	1 ppb	<5 sec	10.0-99.9 ppm	0.1 ppm	<5 sec	100-199 ppm	1 ppm	<5 sec
0-9999 ppb	1 ppb	<5 sec								
10.0-99.9 ppm	0.1 ppm	<5 sec								
100-199 ppm	1 ppm	<5 sec								
Measurement Accuracy:	(Isobutylene with 10.6 eV lamp) 20 ppb or 10% of reading									
PID Detector	Easy access to lamp and sensor for cleaning and replacement.									
Correction Factors	102 built-in VOC gases									
Calibration	Two-point field calibration of zero and standard reference gas.									
Background Display	User selectable to monitor or cancel background level.									
Calibration Memory	Eight calibration curves, alarm									

GENERAL INFORMATION

	limits, span values, and calibration date.
Robust inlet probe	Flexible 5" tubing
Large Keypads	One operation key and two programming keys.
Direct Readout	Instantaneous, TWA, STEL and peak values; battery voltage and elapsed time.
Intrinsic Safety	UL & cUL Class 1, Division I, Group A, B, C, D (US & Canada), CE 0575 Ex II 1G DEMKO 03 ATEX 0204759X Eex ia IIC T4 (Europe)
EM Interference	No effect when exposed to 0.43 W/cm ² RF interference (5 watt transmitter at 12 inches).
Alarm Setting	Separate preset alarm limit settings for Low, High, STEL and TWA alarm.
Operating Mode	Survey or Hygiene, user selectable
Audible Alarm	90 dB buzzer
Visual Alarm	Flashing red LED
External Alarm	Optional plug in pen size vibration alarm.
Alarm mode	Latching or automatic reset (non-latching).
Datalogging	15,000 points with time/date. Header information include monitor serial number, user ID, site ID, date, and time.
Communication	Download data and upload instrument setup from PC through RS-232 link to serial port. Software compatible with Windows 95, 98 and NT.

GENERAL INFORMATION

Remote Control	Power On/Off and data logging through RS-232 port.
Analog Output	Calibrated output, user selectable full-scale range.
Sampling pump	Internal integrated flow rate 400 cc/minute
Low Flow Alarm	Auto shut off pump at low flow condition.
Temperature	14°F to 113°F (-10°C to 40°C)
Humidity	0% to 95% relative humidity (non-condensing)
Attachment	Wrist strap

2 Operation of ppbRAE

The ppbRAE PPB VOC Monitor has a compact design for use as a broadband VOC gas monitor and datalogger for work in hazardous environments. It gives real-time measurements while activating alarm signals whenever the exposure exceeds preset limits. Prior to factory shipment the ppbRAE is preset with default alarm limits and the sensor is pre-calibrated with standard calibration gas. However, the user should calibrate the instrument before first use. After the monitor is fully charged and calibrated, it is ready for immediate operation.

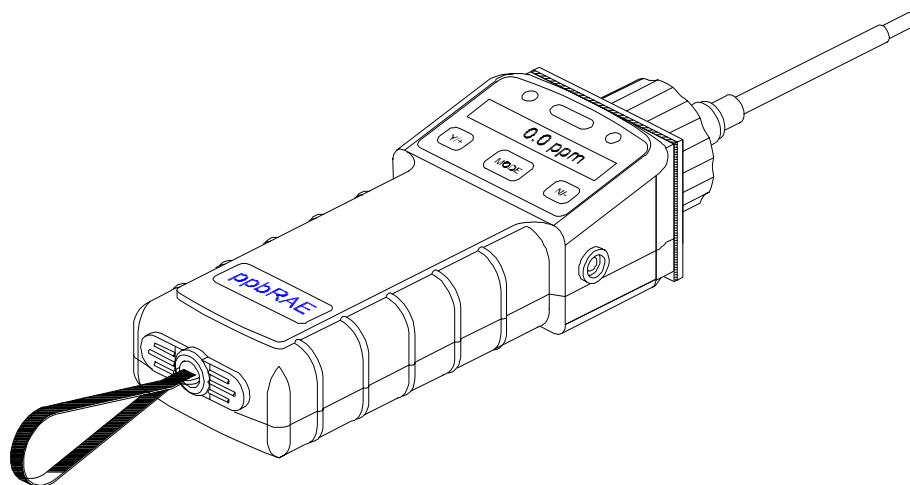

Figure 2-1. ppbRAE

2.1 Physical Description

The main components of the ppbRAE PPB VOC monitor include:

- Three keys for the user to interact with the monitor: 1 operation key and 2 programming keys for normal operation or programming of the monitor.
- LCD display with backlight for direct readout and calculated measurements.
- Buzzer and red LED's for alarm signaling whenever the exposures exceed preset limits.
- Wrist strap
- Charge contact for plugging directly to the charging station
- Gas entry and exit ports
- Serial communication port for PC interface
- External alarm and analog output port
- Protective rubber cover

2.2 Keys and Display

Figure 2.2 shows the LCD display and the keypad on the front panel of the monitor. The function of the 3 keys during normal operation are summarized below:

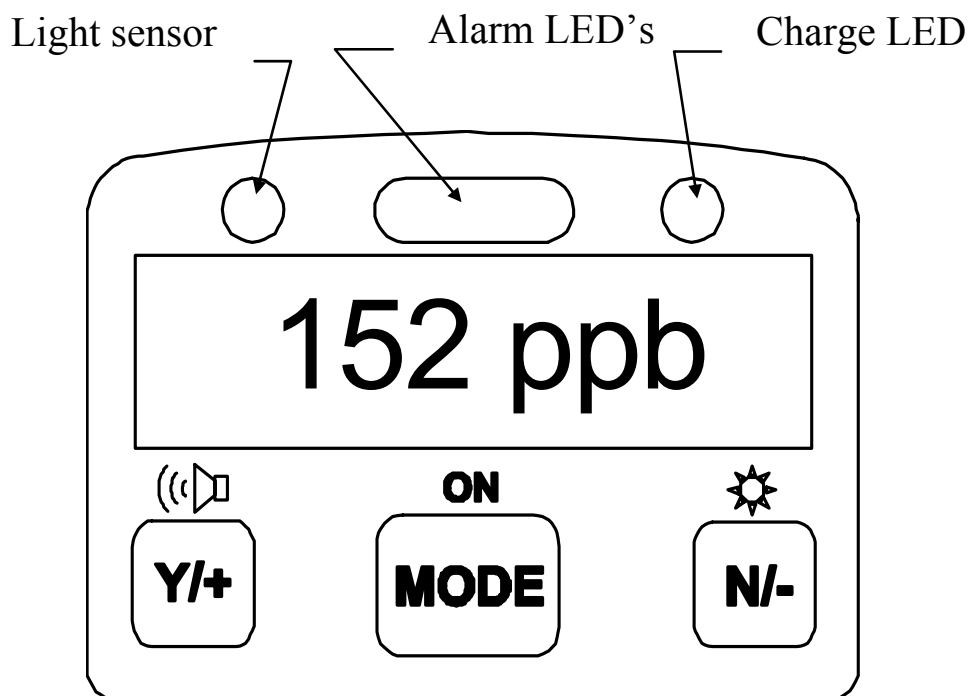

Figure 2-2. Liquid Crystal Display and Keypad

Key	Function in Normal Operation
[MODE]	Turns the power on/off and steps through the menu items.*
[N/-]	Toggles the back light on/off; negative acknowledgement/decrement of value.
[Y/+]	Starts the measurement; positive acknowledgement/increment of value.

* Press the [MODE] key momentarily to step through menu items. To save time, press any key while a message is scrolling to skip to the end of the message.

2.3 Power On/Off

To turn ON the ppbRAE monitor, press the [MODE] key for one second and release. The audio buzzer will beep once and the air pump will turn on. The display will show “ON!..” and then “Ver n.nn” to indicate the unit’s current firmware version number. Displayed next are the serial number, model number, operating mode, current date and time, unit internal temperature, gas selected, high, low, STEL, TWA/AVG alarm limits, battery voltage, and shut off voltage. Also displayed are internal mode settings such as User mode, Alarm mode, datalog time remaining and log periods in the respective order.

To turn OFF the ppbRAE monitor, press and hold the [MODE] key for 5 seconds. The monitor will beep once per second during the power-down sequence with a count down timer showing the number of remaining seconds. The message “Off!..” flashes on the LCD display and the display will go blank indicating that the monitor is turned off.

Data protection during power off

When the monitor is turned off, all the current real time data including the last measured values are erased. However, the datalog data is preserved in non-volatile memory. Even if the battery is disconnected, the datalog data will not be lost. While the power is off, the real time clock will continue to operate until the battery is completely drained (usually in four to five days without recharging). If the battery is completely drained or is disconnected from the monitor for more than 30 minutes, the real time clock will be lost. In this case, the user needs to enter the real time clock information again, as described in Section 4, or send the clock information from the PC clock during configuration through the PC communication connection.

2.4 Operation

The ppbRAE PPB VOC monitor has two operation modes: Survey and Hygiene mode. The Survey mode allows the user to manually start and stop the monitoring/ measuring operation and display certain exposure values. In the Hygiene mode, the monitor runs continuously after the monitor is turned on.

2.4.1 Survey Mode

After the monitor is turned on, it runs through the start up menu. Then the message “Ready..” is displayed (see figure below). At this point, the user has two options: (1) step through the operation menu, or (2) take a measurement.

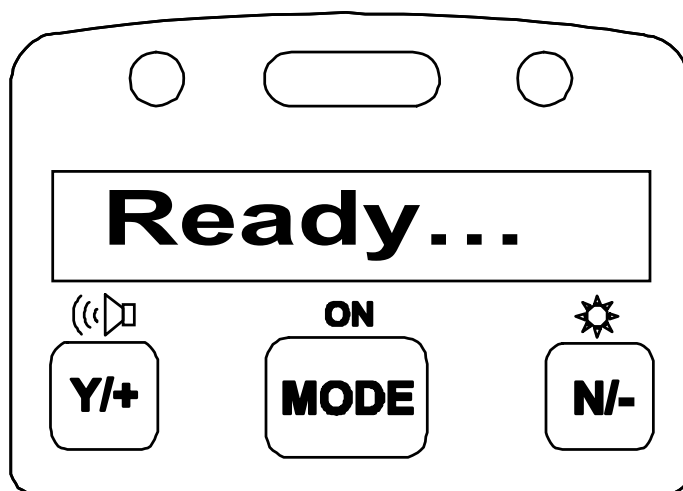

Figure 2-3. Survey mode Ready

Press the [MODE] key to cycle through the idle operation menu. The PID sensor and pump are turned off during this idle operation.

Main operation menu displays include:

- “Ready...”
- Avg reading
- Peak reading
- Run time
- Current battery voltage and shut down voltage
- Date, time, and temperature
- Log on/off?
- PC communication?
- Survey, Site ID, and Gas Name

The displays are arranged in a “round robin” order:
 To choose a specific display, press the [MODE] key one or more times until the desired display appears.

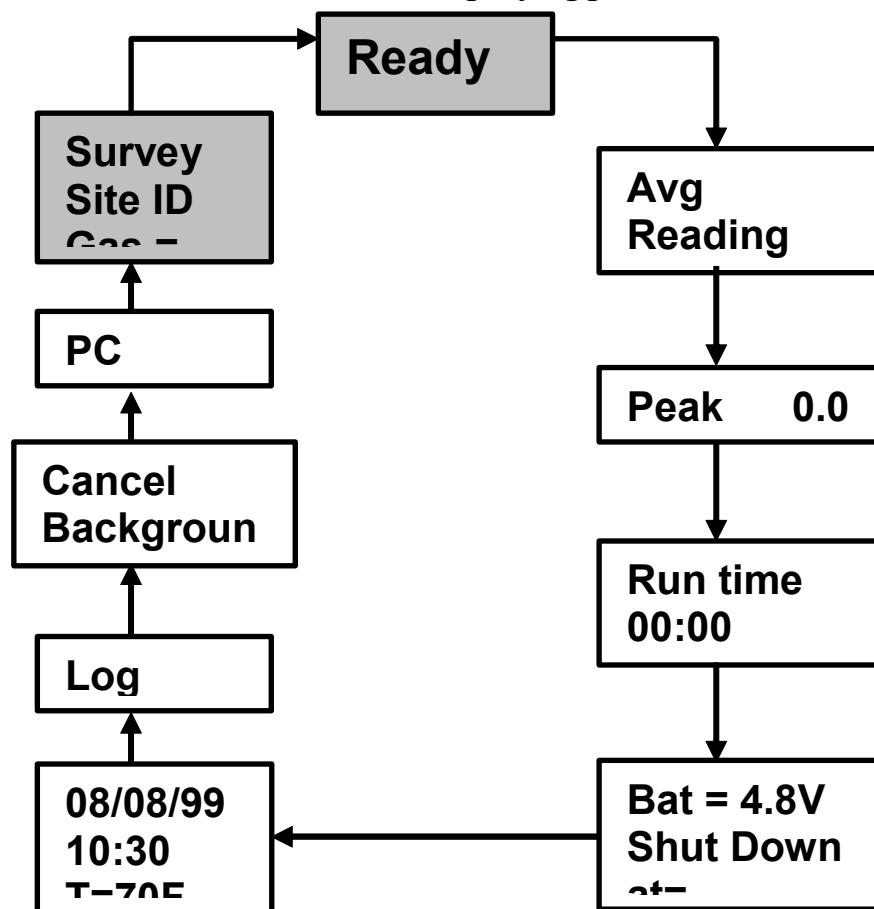

Figure 2-4. Survey Mode Flowchart

Note: To get back to “Ready” mode from any of the above displays, press the [MODE] key repeatedly until the “Ready” message reappears.

More details on the Main Operation Menu:

1. **READY:** The monitor is ready to take a measurement. Press the [MODE] key to advance to the next menu display. Or Press the [Y/+] key to start a measurement. (Read “Taking a Measurement” on page 2-11 for details)
2. **AVERAGE READING:** Running average since the start of the measurement.
3. **PEAK READING:** The highest instantaneous reading since the start of the measurement. If the [Y/+] key is pressed while the peak reading is displayed, the unit will confirm the clear of the peak value. If the [Y/+] key is pressed again, the peak value will be cleared and the display will return to the “Ready” message or instantaneous reading.
4. **RUN TIME:** The current measurement has been last.
5. **CURRENT BATTERY VOLTAGE and SHUT DOWN VOLTAGE:** The present battery voltage is displayed.
6. Note: A fully charged battery pack should show 4.8 volts or higher. When the battery voltage falls below 4.4 volts, a flashing “Bat” will appear as a warning message. When the battery voltage falls below 4.2 volts, there are about 20-30 minutes of run time left before the monitor turns off automatically.
7. **DATE, TIME, and TEMPERATURE:** This menu displays the current date (month/day/year), time (24-hour format), and internal unit temperature in degrees Fahrenheit.
8. **LOG ON/OFF?** Allows the user to start datalogging of the current measurement. A

superscript “L” flashes in the measurement display when datalogging is on.

9. Note: Before datalogging can be turned on, this function must be enabled as described in Section 4.6.4.
10. **CANCEL BACKGROUND?:** The user has the option of reading the instantaneous data as an incremental value from the background readings. The count shown will be the amount detected, minus the background. The monitor will display “Cancel Background?” To accept this option, press the [Y/+] key, otherwise, press the [N/-] key to continue scrolling. If the background reading has already been cancelled, a superscript “+” flashes in the measurement display. To reinstate the background, scroll to where the monitor displays “Show Background?” and press the [Y/+] key. The datalog function will continue to record values that include the background whether or not it is shown in the instantaneous readings.
11. **PC COMMUNICATION:** Allows the user to upload data from the ppbRAE to a Personal Computer (PC) or send/receive configuration information between a PC and the ppbRAE. Connect the monitor to a serial port of a PC, and start the ppbRAE application software. Press the [Y/+] key and the LCD displays “Pause monitor, ok?” Press the [Y/+] key one more time, the display shows “Comm...” The monitor is now ready to receive commands from the PC.
12. **CURRENT OPERATING MODE:** The monitor displays the current operating mode (e.g. “Survey”), the site ID, the gas name and then returns to

“Ready..” To choose a specific display, press the [MODE] key one or more times until the desired display appears.

Taking a measurement:

There are two ways to start a measurement: (1) operating in the Hygiene mode and (2) manually starting and stopping measurement in the Survey mode. To start a measurement in the Hygiene mode, please refer to Section 4.7.1 on “Change Op mode.” To start a measurement in Survey mode, the ppbRAE monitor must first be in the “Ready...” mode. This is the mode that the monitor normally powers up.

Measurement phases:

- Ready
- Start measurement
- Measurement display and datalogging
- Stop measurement

Ready:

The ppbRAE monitor is ready to start a sample.

Start Measurement:

Press the [Y/+] key to start the measurement cycle. Display will show the site ID and then the gas selected for measurement. The pump will start and the reading will be displayed.

Measurement Display and Datalog:

Instantaneous readings of the gas concentration in parts per billion (ppb) are updated every second. A flashing superscript “L” is displayed when datalogging is on. Datalog information is saved only after one full datalog period is completed (see Section 4.6.5).

Stop Measurement:

Press the [MODE] key and the display shows “STOP?”
Press the [N/] key to continue measurement and the [Y/+] key to stop the measurement and datalog the event. The pump stops automatically when measurement is stopped.

Automatic Increment of Site ID:

Every time a measurement is taken, the site ID will be incremented by one automatically in the Survey mode.

Variable Alarm Signal:

During the Survey mode operation, if the measurement exceeds the lower limit, the buzzer, and flashing alarm will be activated. The frequency of the alarm is proportional to the measurement value. When the measurement value is slightly above the low alarm, the buzzer and LED will beep and flash once a second. When the measurement value reaches the high alarm limit, the buzzer and LED will beep and flash 7 times per second.

2.4.2 Hygiene Mode

In the Hygiene mode, the unit will continuously take measurements, once the power is turned on. After the initial start-up sequence displaying the current monitor settings, the LCD continues to display the instantaneous readings.

The Hygiene operation menu displays include:

- Real time readings in ppb
- Current TWA/Avg, STEL, and Peak values
- Run time
- Current battery voltage and shut down voltage
- Date, time, and temperature
- Log on/off?
- Gas name
- PC communication?
- Hygiene

To choose a specific display, press the [MODE] key one or more times until the desired display appears.

Note: To get back to instantaneous reading from any of the above displays, press the [MODE] key repeatedly until the “XX.X ppb” display appears.

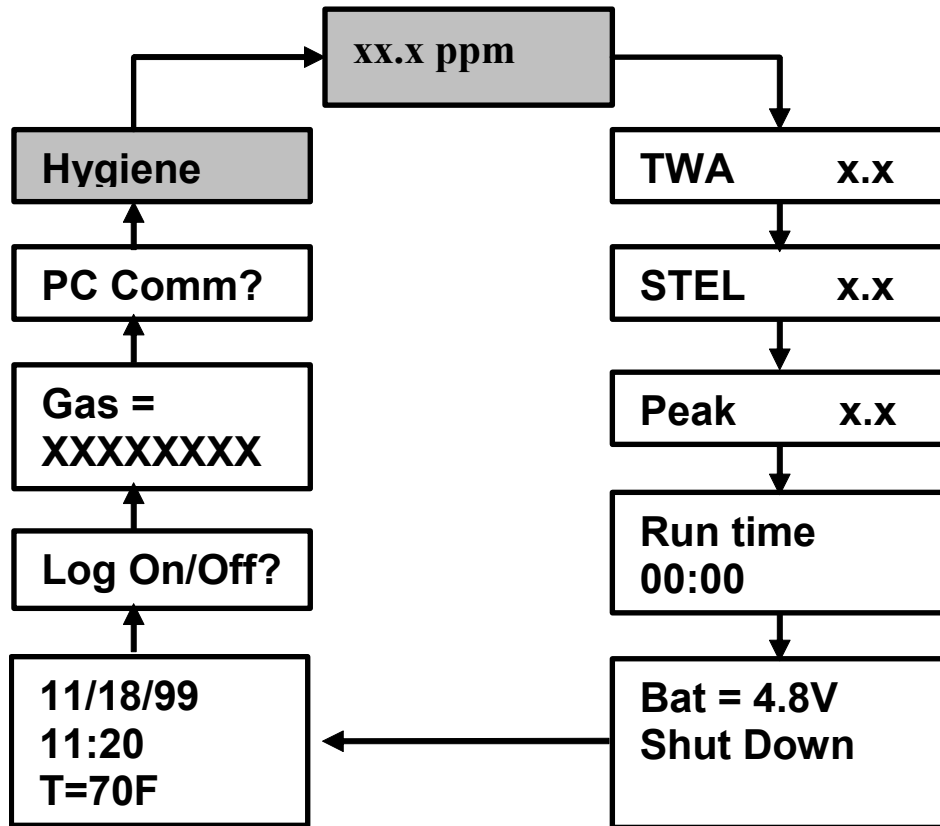

Figure 2-5. Hygiene Mode Flowchart

2.5 Alarm Signals

During each measurement period, the gas concentration is compared with the programmed alarm limits (gas concentration alarm limit settings: Low, High, TWA, and STEL). If the concentration exceeds any of the preset limits, a loud buzzer and red flashing LED are activated immediately to warn the user of the alarm condition.

In addition, the ppbRAE will alarm if one of the following conditions occurs: Battery voltage falls below a pre-set voltage level (4.4 V), failure of the UV lamp, the pump stalls, or when the datalog memory is full. When the low battery alarm occurs, there will be approximately 20-30 minutes of operating time remaining. When the battery voltage falls below 4.2 V, the monitor will turn off automatically.

Table 2-1. Alarm Signal Summary

Condition	Alarm Signal
Gas exceeds “High Alarm” limit	3 beeps/flashes per second
Gas exceeds “Low Alarm” limit	2 beeps/flashes per second
Gas exceeds “TWA” limit	1 beep/flash per second
Gas exceeds “STEL” limit	1 beep/flash per second
Pump failure	3 beeps/flashes per second plus “Pump” message on LCD
PID lamp failure	3 beeps/flashes per second plus “Lamp” message on LCD
Low battery	1 flash per second, 1 beep per minute plus “Bat” message on LCD
Memory full	1 flash per second plus “Mem” message on LCD

Alarm Signal Testing:

Under normal non-alarm conditions, it is possible to test the ppbRAE LED and buzzer in the Special Diagnostic Mode (see Section 8 for details).

2.6 Alarm Limits & Calibration

The ppbRAE portable VOC monitor is factory calibrated with standard calibration gas, and is programmed with default alarm limits. There are 102 gas settings stored in the library. Some examples of calibration and alarm limits are shown below. Refer to Section 4 for programming procedures to select a different gas, perform a calibration or set new alarm limits.

Table 2-2 Factory Calibration & Preset Alarm Limits

Cal Gas	Span	Low	High	TWA	STEL
Isobutylene	10,000	10,000	25,000	10,000	25,000□
Hexane, n-	10,000	50,000	75,000	50,000	75,000
Xylene, m-	10,000	100,000	150,000	100,000	150,000
Benzene	5,000	1,000	2,500	500	2,500
Styrene	10,000	20,000	40,000	20,000	40,000
Toluene	10,000	50,000	100,000	50,000	100,000
Vinyl Chloride	10,000	5,000	10,000	5,000	10,000
Custom	5,000	2,000	5,000	2,000	5,000□

2.7 Integrated Sampling Pump

The ppbRAE PPB VOC monitor includes an integrated sampling pump. This is a diaphragm type pump that provides 450-550 cc/minute flow rate.

The pump turns on when a measurement is started, and turns off when the sample is manually stopped in the Survey mode or when the unit is turned off from the Hygiene mode.

If liquid or other objects are pulled into the inlet port filter, causing the pump to stall, the monitor will detect the obstruction and shut down the pump immediately. The alarm will be activated and a flashing error message “Pump” will be also displayed on the LCD display.

The user needs to acknowledge the pump shut off condition by clearing the obstruction and pressing the [Y/+] key to restart the pump.

The pump stall threshold is set in the special Diagnostic Mode (Section 8).

2.8 Back Light

The LCD display is equipped with an LED back light to assist in reading the display under poor lighting conditions. Pressing and holding the [N/-] key for one second in normal operation can turn the back light on. Pressing [N/-] a second time can turn off the backlight. If the [N/] key is not pressed, the back light will be turned off automatically after a pre-programmed time-out period to save power. In addition, the ambient light is sensed and the back light will be turned on automatically if the ambient light is below a threshold level. The back light is turned off automatically when the ambient light exceeds the threshold level.

See Section 8 for instructions on how to set the light threshold level.

Note: The LED backlight consumes about 20-30% of the total average current, when the instrument is idle or not taking a measurement.

2.9 Datalogging

During datalogging, the ppbRAE Portable VOC monitor flashes a superscript “L,” on the display to indicate that datalogging is enabled. The monitor stores the time stamp, sample number, and measured gas concentration at the end of every sample period (when data logging is enabled). In addition, the following information is stored: users ID, site ID, serial number, last calibration date, and alarm limits. All data is retained (even after the unit is turned off) in non-volatile memory so that it can be down loaded at a later time to a PC.

Datalogging event

When datalogging is enabled, measurement readings are being saved. This data is stored in “groups” or “events.” A new event is created and stored each time the monitor is turned on, or a configuration parameter is changed, or datalogging is interrupted (e.g. communication with the PC during the Hygiene mode). Information, such as the start time, user ID, site ID, gas name, serial number, last calibration date, and the alarm limits will be recorded.

Datalogging sample

After an event is recorded, the unit records a shorter form of the data. This data contains the sample number, time (hour/minute), and gas concentration.

3 Operation of Accessories

The accessories for the ppbRAE include:

- * An AC Adapter (Battery Charger)
- * Alkaline Battery Holder
- * Water Trap Filter

Optional Accessories:

- * Dilution Fitting
- * Calibration Adapter
- * Calibration Regulator and Flow Controller
- * Organic Vapor Zeroing Kit

3.1 Standard Kit and Accessories

1. An AC Adapter (Battery Charger)

WARNING!

To reduce the risk of ignition of hazardous atmospheres, only recharge battery in areas known to be non-hazardous. Remove and replace battery only in areas known to be non-hazardous.

Ne charger les batteries que dans emplacements désignés non dangereux.

A battery charging circuit is built into the ppbRAE monitor. It only needs a regular AC to 12 V DC adapter (wall mount transformer) to charge the monitor.

To charge the battery inside the ppbRAE monitor:

1. Power off the monitor.
2. Connect the AC adapter (or the optional automotive charging adapter) to the DC jack on ppbRAE monitor. If the unit was off, it will automatically turn on.
3. The first message displayed will be “Deep discharge?” The unit will ask this question three times. If the user wants to discharge the battery pack, affirm this query with the [Y/+] key, otherwise the unit will move on to the charge mode directly.
4. While charging, the display message will alternate between “Charging” and “Bat=x.xV” (x.x is the present battery voltage). The LED should be red in color when charging.
5. When the battery is fully charged, the LED will change from red to green and the message “Fully charged” will appear on the display. After the battery is fully charged, the unit will enter the “trickle charge” mode. In this mode, the red LED

will turn on for several seconds each minute to maintain the full charge.

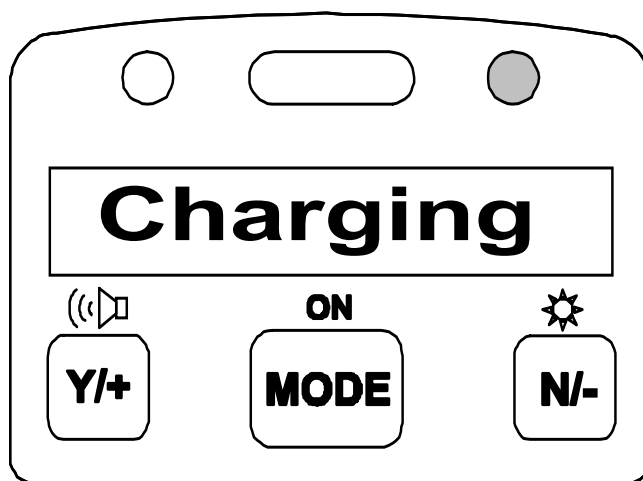

Figure 3-1. Charging the unit.

A completely discharged ppbRAE monitor will be charged to full capacity within 10 hours. The battery will be drained slowly even if the monitor is turned off. If the monitor has not been charged for 7-10 days, the battery voltage will be low.

The factory-supplied battery is designed to last for 10 hours of normal operation (no alarm, no back light condition), for a new battery under the best condition. As the battery becomes older or is subject to adverse conditions (such as cold ambient temperature), the battery capacity will be reduced significantly.

2. Alkaline Battery Holder

An alkaline battery holder is supplied with each ppbRAE. It accepts four AA size alkaline batteries and can be used in place of the Ni-MH or Ni-Cd battery pack to provide approximately 12-14 hours of operation. The adapter is intended to be used in emergency situations when there is no time to charge the Ni-Cd or Ni-MH battery pack.

To install the adapter, remove the cover of the battery compartment. Remove the Ni-Cd or Ni-MH battery pack from the battery compartment and replace with the alkaline battery adapter. Replace the battery compartment cover.

The internal charging circuit is designed to prevent damage to alkaline batteries and the charging circuit when alkaline batteries are installed inside the monitor.

Note: The AA Alkaline battery adapter supplied by RAE Systems Inc. is intrinsically safe!

3. Water Trap Filter

The water trap filter is made of PTFE (Teflon[®]) membrane with a 10-micron pore size to prevent water from being sucked into the sensor manifold, which would cause extensive damage to the monitor. It will also remove any dust and other particles from entering the monitor and prolong the operating life of the sensor.

To install the water trap, simply insert it to the front of the inlet tube of the ppbRAE monitor.

3.2 Optional Accessories

1. Dilution Fitting

The user may wish to install a dilution fitting on the inlet to dilute the gas samples. One application for a dilution fitting is to measure organic gas when the concentration exceeds the upper limit of the sensor range.

Make sure to set the dilution ratio in the programming mode (see Section 4.7.9) so that the correct gas reading will be displayed when the dilution fitting is used.

WARNING: To use a dilution fitting, the user must have the monitor located in a clean atmosphere outside of confined spaces and use a remote access probe or Tygon tubing to measure the gas concentration inside confined spaces.

2. Calibration Adapter

The calibration adapter for the ppbRAE is a simple 6- inch Tygon tubing with a metal adapter on one end. During calibration, simply insert the metal adapter into the regular gas inlet probe of the ppbRAE and the tubing to the gas regulator on the gas bottle.

3. Calibration Regulator & Flow Controller

The Calibration Regulator and Flow controller is used in the calibration process. It regulates the gas flow rate from the Span gas cylinder into the gas inlet of the ppbRAE monitor during the calibration process. The maximum flow rate allowed by the flow controller is 0.5L/min (500 cc/min.). Alternatively, a Demand-flow Regulator or a Tedlar gas bag may be used to match the pump flow precisely.

4. Organic Vapor Zeroing Kit (Charcoal Filter)

The Organic Vapor Zeroing Kit is used for filtering organic air contaminants that may affect the zero calibration reading. To use the Organic Vapor Zeroing Kit, simply connect the filter to the inlet port of the ppbRAE.

4 Programming ppbRAE

The ppbRAE Monitor is built with a microcomputer to provide programming flexibility. Authorized users can recalibrate the monitor, change the alarm limits, change the site ID, user ID, lamp type, and real time clock, etc. Programming is menu-driven to provide intuitive end-user operation. The display shows the menu options and the keypad used for menu selection and data entry.

4.1 Programming Mode

The programming mode allows users to change the setups in the monitor, calibrate the monitor, modify the sensor configuration and enter user information, etc. The programming mode has four menu items. Each menu item includes several sub-menus to perform additional programming functions. Appendix A shows a more detailed menu tree structure.

Table 4-1. Programming Menu

Calibrate/Select Gas?
Change Alarm Limits?
View or Change Datalog?
Change Monitor Setup?

Once inside the programming mode, the LCD will display the first menu. Each subsequent menu item can be viewed by pressing the [N/] repeatedly until the desired menu is displayed. To enter the sub-menu of a particular menu, press [Y/+] key, the sub-menu will be displayed.

Return to Operation mode: To exit the programming mode and return to operation, press the [MODE] key once at any of the programming menu displays.

4.2 Keys for Programming Mode

The three keys perform a different set of functions during the programming mode as summarized below.

Table 4-2. Keys for Programming Mode

Key	Function in Programming Mode
[MODE]:	Exit menu when pressed shortly or exit data entry mode when pressed and held for 1 second.
[Y/+]:	Increase alphanumerical value for data entry or confirm (yes) for a question.
[N/-]:	Decrease alphanumerical value for data entry or deny (no) for a question

4.3 Entering into Programming Mode

1. Turn on the ppbRAE monitor and wait for the “Ready..” message or the instantaneous reading display “xxx ppb” message displayed.
2. Press and hold down both the [N/] and [MODE] keys for three seconds to enter into the programming mode. This delay is to prevent the user from entering into the programming mode accidentally.
3. The first menu item “Calibrate/select Gas?” will be displayed.
4. Release both the [MODE] and [N/] keys simultaneously to start the programming mode.
5. Press the [N/] key to scroll to the next menu item of the programming menu. Press the [Y/+] key to select the displayed menu item.

The following Sections 4.4 - 4.7 describe the details of each menu option.

4.4 Calibrate and Select Gas

WARNING:

The calibration of all newly purchased RAE Systems instruments should be tested by exposing the sensor(s) to known concentration calibration gas before the instrument is used or put into service.

For maximum safety, the accuracy of the ppbRAE should be checked by exposing the sensor(s) to known concentration calibration gas before each day's use.

In the first menu of the programming mode, the user can perform functions such as calibration of the ppbRAE Monitor, select default cal memories, and modify cal memories (see Table 4-3).

Table 4-3. Calibrate/Select Gas Sub-Menu

Zero Cal?

Span Cal?

Select Cal Memory?

Change Span Value?

Modify Cal Memory?

Change Correction Factor?

Calibrating the ppbRAE monitor is a two-point process using “fresh air” and the standard reference gas (also known as span gas). A “fresh air” or zero calibration, which contains no detectable VOC (less than 200 ppb) or bottled air, is used to set the zero point for the sensor. Then a standard reference gas that contains a known concentration of a given gas is used to set the second point of reference.

Note: The span value must be set prior to calibrating for fresh air or span.

In addition to calibrations, the first menu allows the user to store calibrations for up to eight different measurement gases.

The default gas selections are as follows:

Cal Memory #0.....Isobutylene

Cal Memory #1.....Hexane

Cal Memory #2.....Xylene

Cal Memory #3.....Benzene

Cal Memory #4.....Styrene

Cal Memory #5.....Toluene

Cal Memory #6.....Vinyl Chloride

Cal Memory #7.....Custom

All cal memories may be modified to one of 102 preprogrammed chemicals or to a user-defined custom gas. In the gas library, only the gases that can be detected by the installed UV lamp will actually be displayed. If Isobutylene in memory #0 is calibrated and the selected gas in memory #1 to #7 is not calibrated, the correction factor from the library will be used automatically, so the reading for the selected gas will be correct even without calibration. If the selected gas has been calibrated, no correction factor is applied.

To change a default gas to a library or custom gas, first go to Select Cal Memory (Section 4.4.3) and then proceed to Modify Cal Memory (Section 4.4.5) to enter the desired gas.

4.4.1 Zero Calibration

This procedure determines the zero point of the sensor calibration curve. To perform a zero air calibration, connect a charcoal filter from the ppbRAE inlet to a clean ambient air without any detectable contaminants, or connect to a cylinder of zero grade air. Caution: most commercial zero air is not specified as to its impurities at ppb levels.

Note: The charcoal filter has a check box so that user can mark off a box each time the filter has been used. The charcoal filter should be replaced after four calibrations.

4.4.2 Span Calibration

This procedure determines the second point of the sensor calibration curve for the sensor. A cylinder of standard reference gas (span gas) fitted with a 500 cc/min. flow-limiting regulator or a flow-matching regulator is needed to perform this procedure. Choose the 500 cc/min. regulator only because the flow rate matches the flow rate of the pump inside. Alternatively, the span gas can first be filled into a Tedlar Bag. Connect the calibration adapter to the inlet port of the ppbRAE Monitor, and connect the tube to the regulator or Tedlar bag.

1. Before executing a span calibration, make sure the span value has been set correctly (see next sub-menu).
2. Make sure the monitor is connected to one of the span gas sources described above.
3. Press the [Y/+] key at the “Span Cal?” to start the calibration. The display shows the gas name and the span value of the corresponding gas.
4. The display shows: “Apply gas now!” Turn on the valve of the span gas supply.
5. Display shows “wait... 30” with a count down timer showing the number of remaining seconds while the monitor performs the calibration.
6. To abort the calibration, press any key during the count down. The display shows “Aborted!” and return to “Span Cal?” sub-menu.
7. When the count down timer reaches 0, the display shows the calibrated value.

Note: The reading should be very close to the span gas value.

PROGRAMMING

8. During calibration, the monitor waits for an increased signal before starting the countdown timer. If a minimal response is not obtained after 35 seconds, the monitor displays “No Gas!” Check that the span gas valve is on and for lamp or sensor failure before trying again.
9. The calibration can be started manually by pressing any key while the “Apply gas now!” screen is displayed.
10. After the span calibration is completed, the display will show the message “Span Cal Done! Turn Off Gas.”
11. Turn off the flow of gas. Disconnect the calibration adapter or Tedlar bag from the ppbRAE Monitor.
12. Press any key to return back to “Span Gas Cal?”

4.4.3 Selecting Cal Memory

This function allows the user to select one of eight different memories for gas measurement. The gas concentration reading will be automatically calculated using the correction factor inside the monitor and the calibration data in cal memory #0 if the gas is not calibrated. The user may calibrate the selected gas for that memory if no automatic conversion is wanted. The default gas selections are listed in Section 4.4.

1. “Select Cal Memory?” is the third sub-menu item in the Calibration sub-menu. Pressing the [Y/+] key, the display will show “Gas =” gas name followed by “Mem # x?”
2. Press [N/] to scroll through all the memory numbers and the gas selections respectively. Press [Y/+] to accept the displayed Cal Memory number.
3. After the [Y/+] key is pressed, the display shows “Save?” Press the [Y/+] key to save and proceed. Press [N/] to discard the entry and advance to the next sub-menu.
4. If the gas in a newly selected Cal Memory number is not calibrated, the display shows “CF= x.xx”. A correction factor with the value “x.xx” will be applied.
5. If the gas of a newly selected cal memory number has been calibrated previously, the display shows “Last calibrated xx/xx/xx”.

4.4.4 Changing the Span Value

This function allows the user to change the span values of the calibration gases.

1. “Change Span Value?” is the fourth sub-menu item in the Calibration sub-menu.
2. Press [Y/+], display shows the gas name and the span value. A cursor will blink at the first digit of the Span value. To modify the span gas value, go to Step 3. Otherwise, press and hold the [MODE] key for one second to accept the previously stored span gas value and move to the next sub-menu.
3. Starting from the left-most digit of the span gas value, use the [Y/+] or [N/] keys to change the digit value and press the [MODE] key momentarily to advance to the next digit. Repeat this process until all digits are entered. Press and hold the [MODE] for one second to exit.
4. The display shows “Save?” To accept the new value, press the [Y/+] key. Press the [N/] key or the [MODE] key to discard the change and move to the next sub-menu.

4.4.5 Modifying the Cal Memory

If the current cal memory number selected is not memory 0, users will be prompted whether to modify the settings of the selected cal memory. Press [Y/+] to modify the cal memory and [N/] to go to the next sub-menu. Once [Y/+] is pressed the LCD display will show the current memory number, current gas selected and prompt the user for acceptance of the current gas selected. If the current cal memory is #0, the display will show a message “Cannot modify Mem #0!!”

1. Press [N/] to modify the gas selection if desired. Or press the [Y/+] key to skip the change of gas selection, and proceed to the next sub-menu.
2. After pressing [N/], the display shows “Copy gas from library?” Press [Y/+] to accept or [N/] for the next sub-menu, “Enter custom gas?”
3. In the “Copy gas from library” sub-menu, use the [Y/+] and [N/] keys to scroll through the selections in the library. Press the [MODE] key momentarily to select the gas. The display shows “Save?” Press [Y/+] to save or [N/] to discard the changes and proceed to the next sub-menu.
4. In the Custom gas sub-menu, the user can enter the gas name. Press the [Y/+] or [N/] keys to cycle through all 26 letters and 10 numerals. Press the [MODE] key momentarily to advance to the next digit. The flashing digit will move to the next digit to the right. Repeat this process until all digits (up to 8 digits) of the custom gas name is entered.
5. Press and hold the [MODE] key for one second to exit the name entry mode. The display will show “Save?” Press [Y/+] to save the entry, or [N/] to discard the changes.

4.4.6 Changing the Correction Factor

This function allows the user to change the Correction Factor of the standard calibration gas (except for Cal Memory #0).

1. “Change Correction Factor?” is the sixth sub-menu in the Calibration sub-menu.
2. Press the [Y/+] key. The display shows the gas name, then the correction factor.
3. A cursor blinks at the left-most digit of the correction factor. If the user wants to modify the correction factor, go to step Otherwise, press and hold the [MODE] key for one second to accept the previously stored correction factor value and return to the first sub-menu of the calibrate/select gas menu.
4. Starting from the left-most digit of the correction factor, use the [Y/+] or [N/] keys to change the digit value and press the [MODE] key momentarily to advance to the next digit, the cursor will move to the next digit to the right. Repeat this process until all digits are entered. Press and hold the [MODE] key for one second to exit.
5. The display shows “Save?” To confirm the new value, press the [Y/+] key to accept the change. Press the [N/] key or the [MODE] key to discard the change and return to the first sub-menu of the Calibrate and Select Gas menu.

4.5 Changing Alarm Limits

In this menu, the user can change the high and low alarm limits, the STEL limit and the TWA limit. See Table 4-4 below. Press the [Y/+] key and the display shows the current gas selected followed by the first sub-menu item below.

Table 4-4. Alarm Limit Submenu

Change High Alarm limit?

Change Low Alarm limit?

Change STEL limit?

Change TWA limit?

1. Scroll through the Alarm Limit sub-menu using the [N/] key until the display shows the desired limit to be changed, e.g., "High limit?", "STEL limit?", etc.
2. Press the [Y/+] key to select the desired limit. The display shows a flashing cursor on the left-most digit of the previously stored alarm limit.
3. To modify this limit value, use the [Y/+] or [N/] keys to change the digit value and press the [MODE] key momentarily to advance to the next digit. The flashing digit will move on to the next digit to its right. Repeat this process until the new limit values are entered. Press and hold the [MODE] key for one second to exit data entry mode.

4. If there is any change to the existing value, the display shows “Save?” Press the [Y/+] key to accept the new value and move to the next sub-menu. Press the [N/] key to discard the changes and move to the next sub-menu.

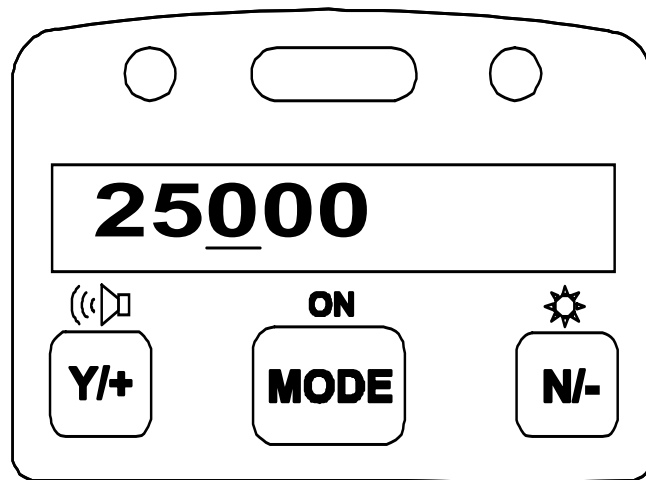

Figure 4-1. Set Alarm Limit display

4.5.1 Changing the Low Alarm Limit

The second sub-menu item in the Alarm Limit sub-menu allows the user to change the Low Alarm limit. The LCD displays “Low limit?” To change the Low Alarm limit, press the [Y/+] key, or press the [N/] key to advance to the next sub-menu in Table 4-5.

1. Press [Y/+] and the display will show a flashing cursor on the left-most digit of the previously stored Low alarm limit.
2. To modify this limit value, use the [Y/+] or [N/] keys to change the digit value and press the [MODE] key momentarily to advance to the next digit. The flashing digit will move on to next digit to its right. Repeat this process until the new limit values are entered. Press and hold the [MODE] key for one second to exit the data entry mode.
3. If there are any changes to the existing value, the display shows “Save?” Press the [Y/+] key to accept the new value and move to the next sub-menu. Press the [N/] key to discard the changes and move to the next sub-menu.

4.5.2 Changing the STEL Limit

This sub-menu item allows the user to change the STEL limit. The display shows “STEL limit?”

1. Press the [Y/+] key and the display will show a flashing cursor on the left-most digit of the previously stored STEL limit.
2. To modify this limit value, use the [Y/+] or [N/] keys to change the digit value and press the [MODE] key momentarily to advance to the next digit. The flashing digit will move on to the next digit to its right. Repeat this process until the new limit values are entered. Press and hold the [MODE] key for one second to exit the data entry mode.
3. If there are any changes to the existing value, the display shows “Save?” Press the [Y/+] key to accept the new value and move to the next sub-menu. Press the [N/] key to discard the changes and move to the next sub-menu.

4.5.3 Changing the TWA Limit

This sub-menu item allows the user to change the TWA limit. The LCD displays “TWA limit?”

1. Press [Y/+] and the display will show a flashing cursor on the left-most digit of the previously stored TWA limit.
2. To modify this limit value, use the [Y/+] or [N/] keys to change the digit value and press the [MODE] key momentarily to advance to the next digit. The flashing digit will move on to the next digit to its right. Repeat this process until the new limit values are entered. Press and hold the [MODE] key for one second to exit data entry mode.
3. If there are any changes to the existing value, the display shows “Save?” Press the [Y/+] key to accept the new value and move to the next sub-menu. Press the [N/] key to discard the changes and move to the next sub-menu.

4.6 Viewing or Changing the Datalog

The ppbRAE monitor calculates and stores the concentration and ID of each sample taken. In the datalog sub-menu, a user can perform the tasks and functions shown in Table 4-5. Datalog Sub-Menu

Table 4-5. Datalog Sub-Menu.

View Data?

Clear Data?

Change Data Period?

Change Average Type?

4.6.1 Viewing Data (Datalogging)

This function allows the user to review all the data that is stored in the non-volatile datalog memory.

Data is stored in groups or “events.” Each event consists of the event time (hour : minute : second), and measurement values.

For example:

Event/Log #1

Data #1	(10/01/97, 14:35:05, Avg., 0.2 PPM, Max 4.0)
Data #2	(14:35:10, Avg. 0.4, Max 11.0)
Data #3	(14:35:15, Avg. 0.4, Max 11.0)

Event/Log #2

Data #1	(10/03/98, 07:20:30, Avg. 3.4, Max 20.0)
Data #2	(07:20:40, Avg. 0.7, Max 20.0)

1. “View Data?” is the second sub-menu item in the Datalog sub-menu.
2. Press the [Y/+] key and the display shows “Event..” and “Log #1?” (see figure below). Press the [Y/+] key to view the data of the displayed event. Or press the [N/-] key to scroll to next event. If there are no more events, the message “No more events! Start from event #1?” will appear. Press the [Y/+] key, the monitor will jump back to the first event. Press the [N/-] key, the monitor will remain in the last event.
3. Press the [Y/+] key to review the first data of the selected event. The display shows the stored data including the time stamp in hours and minutes, and measurement values.

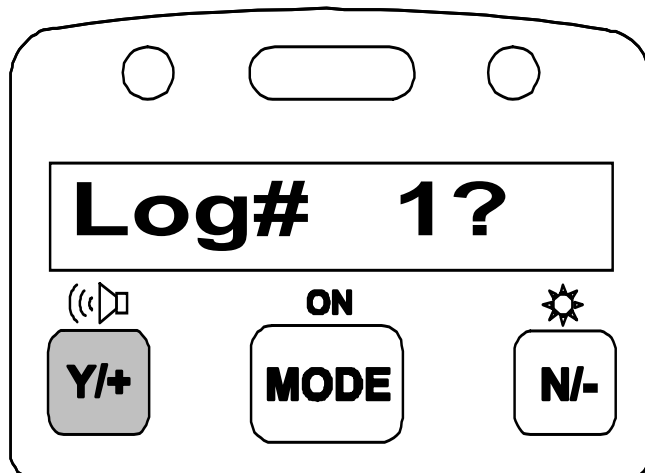

Figure 4-2. Viewing logged data.

Action	Display
	Event, Log# 1?
[Y/+]	08/01/99, 14:20:07, Avg. 150, Max 210 □
[Y/+]	14:20:08, Avg. 150, Max 200

4. Press the [Y/+] or [N/-] keys to move forward or backward to view other data from this event. When the beginning or the end of the event is reached, the message “1st data” or “End data” will appear. Press the [MODE] key to exit the current event.

4.6.2 Clearing Data

This function will erase all data stored in the non-volatile datalog memory.

Note: This function does not change STEL, TWA, Peak, Minimum and run time values which are stored in the regular data memory.

1. “Clear Data?” is the third sub-menu item in the Datalog sub-menu.
2. Press the [Y/+] key to clear the datalog memory. The display shows “Are you sure?”
3. Press the [Y/+] key again to confirm erasure of the datalog memory.
4. Press the [N/-] or [MODE] keys to exit without clearing the datalog memory and move to the next Datalog sub-menu.

4.6.3 Changing the Datalog Period

The datalog period can be programmed from 1 to 3,600 seconds (1 hour).

1. “Change Data Period?” is the fifth sub-menu item in the Datalog sub-menu.
2. Press the [Y/+] key and the display shows “Datalog Period = XXXX” with the left-most digit flashing, where “XXXX” is the previously stored datalog period.
3. To modify this period, starting from the left-most digit, use the [Y/+] or [N/] keys to change the digit value and press the [MODE] key momentarily to advance to the next digit. The flashing digit will move to the next digit to the right. Repeat this process until all four digits of the new period are entered. Press and hold the [MODE] key for one second to exit data entry mode.
4. If there is any change to the existing value, the display will show “Save?” Press the [Y/+] key to accept the new value. Press the [N/] key to discard the changes then move to the next sub-menu.

4.6.4 Changing the Average Type

The user can select either an 8-hour Time Weighted Average (TWA) or a running Average. The running average is simply the average of all instantaneous (1-second) readings since the measurement was started. This average may increase or decrease with time depending on the readings. The TWA is a cumulative value used to estimate the fraction of the 8-hour limit to which the user has been exposed since the start of the measurement. This value can only increase or remain constant, never decrease. Refer to Technical Note 119 for more information on how the TWA is calculated.

1. “Change Average Type?” is the sixth sub-menu in the Datalog sub-menu.
2. Press the [Y/+] key to enter the function.
3. The display will show “Running Average?” or “Time Weighted Average?” depending on the current average type.
4. Press the [N/-] key to toggle between the average types. Press the [Y/+] key to select the displayed average type.
5. If there is any change to the existing setting, the display shows “Save?” Press the [Y/+] key to save the change. Press the [N/-] or [MODE] keys to discard the change and return to the first sub-menu.

4.7 Changing the Monitor Setup

Several monitor specific variables can be changed in this menu. The following is a list of configuration data that can be modified by the user.

Table 4-6. Monitor Setup Sub-Menu

Change Operation Mode?

Change Site ID?

Change User ID?

Change Alarm Mode?

Change User Mode?

Change Date?

Change Time?

Change Lamp?

Change Unit?

Change Pump Speed?

Change Dilution Ratio?

Change External Output?

Change DAC Range?

4.7.1 Changing Operation Mode

The ppbRAE supports two operational modes: Survey and Hygiene mode.

Survey mode: Manual start/stop of measurements and display of certain exposure values.

Hygiene mode: Automatic measurements, running and datalogging continuously and calculates additional exposure values.

1. “Change Op Mode?” is the first sub-menu item in the Monitor Setup menu (Table 4.7).
2. Press the [Y/+] key and the display shows the current user mode: “Op Mode = current mode?”
3. Press the [Y/+] key to accept the currently displayed operation (Op) mode. Press [N/] to toggle to the other operation modes. Press [MODE] to exit this sub-menu and move to the next monitor setup sub-menu.
4. When changing Op mode from the Hygiene to the Survey, the display shows the additional message “Exit from Hygiene?” to prevent accidentally exiting from the Hygiene mode.
5. If there is any change to the existing setting, the display will show “Save?” Press the [Y/+] key to accept or the [N/] key to discard and move to the next sub-menu.
6. Note: If a new Op mode change is saved, display shows “Op Mode changed!!” when exiting out of programming mode.

4.7.2 Changing the Site ID

The user can enter an 8-digit alphanumeric site ID in the programming mode. This site ID will be included in the datalog report.

1. “Change Site ID?” is the second sub-menu item in the Monitor Setup menu (Table 4-6).
2. Press the [Y/+] key and the display shows the current site ID: “Site ID = xxxxxxxx” with the left most digit flashing.
3. Press the [Y/+] or [N/] keys to cycle through all 26 letters and 10 numerals. Press [MODE] momentarily to advance to the next digit. The cursor will move to the next digit to the right. Repeat this process until all eight digits of the new site ID are entered. Press and hold the [MODE] key for one second to exit the data entry mode.
4. If there are any changes to the existing site ID, the display shows “Save?” Press the [Y/+] key to accept the new site ID. Press the [N/] key to discard the change and move to the next sub-menu.

4.7.3 Changing the User ID

The user can enter an 8-digit alphanumeric user ID in the programming mode. This user ID will be included in the datalog report.

1. “Change User ID?” is the third sub-menus item the Monitor Setup menu.
2. Press the [Y/+] key and the display shows the current user ID: “User ID = xxxxxxxx” with the left most digit flashing.
3. Press the [Y/+] or [N/] keys to cycle through all 26 letters and 10 numerals. Press [MODE] momentarily to advance to the next digit. The flashing digit will move to the next digit to the right. Repeat this process until all eight digits of the new user ID are entered.
4. Press and hold the [MODE] key for one second to exit the data entry mode. If there are any changes to the existing user ID, the display shows “Save?” Press the [Y/+] key to accept the new user ID. Or press the [N/] key to discard the changes and move to the next sub-menu.

4.7.4 Changing the Alarm Mode

There are two different alarm modes: Latched and Automatic Reset (Auto Reset) in the ppbRAE that can be selected from the programming menu.

1. “Change Alarm Mode?” is the fourth sub-menu item in the Monitor Setup menu (Table 4-6).
2. Press the [Y/+] key; the display shows the current alarm mode.
3. Press the [Y/+] key to accept the currently displayed alarm mode. Press [N/] to toggle to the other alarm mode. Press [MODE] to exit this sub-menu and move to the next monitor setup sub-menu.
4. If there are any changes to the existing setting, the display will show “Save?” Press the [Y/+] key to save the new change. Or press the [N/] key to discard the change and move to the next sub-menu.

4.7.5 Changing the User Mode

There are two different user modes: Display and Program that can be selected from the programming menu.

1. “Change User Mode?” is the fifth sub-menu item in the Monitor Setup menu (Table 4-6).
2. Press the [Y/+] key; the display shows the current user mode selected.
3. Press the [Y/+] key to accept the currently displayed user mode. Press [N/] key to toggle to the alternate user modes. Press [MODE] to exit this sub-menu and move to the next monitor setup sub-menu.
4. If there are any changes to the existing selection, the display shows messages “Program change” and “Are you sure?” Press the [Y/+] key to confirm the change or press the [N/] key to discard the changes and move to the next sub-menu.

CAUTION:

If the user mode is changed to the Display mode, the user can no longer enter the programming mode. Therefore, the user cannot change the user mode back to the Program mode in the normal mode.

To restore the user mode back to the Program mode, turn the unit off and back on in Diagnostic mode. Next enter the Program mode by holding the [MODE] and [N/] keys for three seconds. Enter the password at the prompt (the default is 0000). Once program mode is entered, go to the “Change Monitor Setup”/“Change User Mode” and change the mode back to Program.

An alternative way to change Display mode back to Program mode is through the PC, utilizing the ProRAE-Suite software (see Section 5.3).

4.7.6 Changing the Date

The ppbRAE monitor is equipped with a real time clock (RTC). The user can enter the correct date and time (see Section 4.7.7) for the real time clock.

1. “Change Date?” is the sixth sub-menu item in the Monitor Setup menu.
2. Press [Y/+] and the display shows the current date “mm/dd/yy” with the left most digit of the date flashing.
3. To modify this value, use the [Y/+] or [N/] keys to change the digit value and press the [MODE] key momentarily to advance to the next digit. The flashing digit will move on to the next digit to its right. Repeat this process until the new date and time values are entered. Press and hold the [MODE] key for one second to exit data entry mode.
4. If there are any changes to the existing value, the display shows “Save?” Press the [Y/+] key to accept the new value or press the [N/] key to discard the changes and move to next sub-menu.

4.7.7 Changing the Time

To change the time in the RTC of the ppbRAE:

1. “Change Time?” is the seventh sub-menu item in the Monitor Setup menu.
2. Press [Y/+] and the display shows the current time in the 24-hour format “hh mm” with the left most digit of the time flashing.
3. To modify this value, use the [Y/+] or [N/] keys to change the digit value and press the [MODE] key momentarily to advance to the next digit. The flashing digit will move on to the next digit to its right. Repeat this process until the new date and time values are entered. Press and hold the [MODE] key for one second to exit data entry mode.
4. If there are any changes to the existing value, the display shows “Save?” Press the [Y/+] key to accept the new value. Press the [N/] key to discard the change and move to the next sub-menu.

4.7.8 Changing the Lamp

There are two UV lamps with different photon energies available for the ppbRAE: 9.8 and 10.6 eV. The user can select any one of the lamps from the programming mode. An 11.7 eV option is also given although currently this lamp is not recommended.

1. “Change Lamp Type?” is the eighth sub-menu item in the Monitor Setup menu (Table 4-6).
2. Press the [Y/+] key; the display shows the current PID lamp selection.
3. Press the [Y/+] key to accept the currently displayed lamp. Press the [N/] key to scroll through the sub-menu for other lamp selections. Press [MODE] to exit this sub-menu and return to the next sub-menu in Table 4-6.
4. If there is any change to the existing selection, the display will show “Save?” Press the [Y/+] to save the new selection or press the [N/] to discard the change and return to the next sub-menu in Table 4-6.

4.7.9 Changing the Units

Table 4-7. Units Sub-Menu

Display Unit = ppb?

Display Unit = ug?

Display Unit = ppm?

Display Unit = mg?

The user can change the display and datalog units from parts per billion (ppb), micrograms per cubic meter (ug), parts per million (ppm), and milligrams per cubic meter (mg).

1. “Change Unit?” is the ninth sub-menu item in the Monitor Setup sub-menu.
2. Press the [Y/+] key, the display should show the current unit “Display Unit = xxx?”
3. Press [Y/+] key to accept the currently displayed unit. Press [N/-] key to toggle to the other units. Press the [MODE] key to exit this sub-menu.
4. If there are any changes to the existing selection, press the [Y/+] key to save the change or press [N/-] key to discard the change.

CAUTION:

The correction factor in the gas library is calculated based on “ppb” and “ppm” units. If either “ug” or “mg” units are selected, the built-in correction factor library is not valid.

The Automatic range is between “ppb” and “ppm” or between “ug” and “mg.” There are no other automatic conversions. When the unit name is changed from “ppb” or “ppm” to “ug” or “mg,” calibration by using a standard “mg” gas is required. The same rule applies when the unit is changed back.

4.7.10 Changing the Output

There are two different external output options: DAC (Analog output) and Alarm in the ppbRAE that can be selected from the programming menu. The alarm output can be used to connect to the optional vibration alarm (vibrator) only. The analog output that represents the gas concentration can be connected to a charter.

1. “Change Output?” is the tenth sub-menu item in the Monitor Setup menu.
2. Press the [Y/+] key and the display shows the current output option selection: “Output = DAC?”
3. Press the [Y/+] key to accept the currently displayed output option. Press [N/] to change to the other external option: “Output = Alarm?” Press [MODE] to exit this sub-menu and move to the next monitor setup sub-menu.
4. If there are any changes to the existing selection, pressing the [Y/+] key the display will show “Save?” Then, press the [Y/+] key to save the change or press [N/] to go back to Step 2.

4.7.11 Changing the Pump Speed

There are two pump speeds of approximately 600 cc/min and 400 cc/min designated as “high” and “low,” respectively.

1. “Change Pump Speed?” is the eleventh sub-menu item in the Monitor Setup menu.
2. Press the [Y/+] key and the display shows the current pump speed: “Pump = Low?”
3. Press the [Y/+] key to accept the currently displayed output option. Press [N/] to change to the other external option: “Pump = High?” Press [MODE] to exit this sub-menu and move to the next monitor setup sub-menu.
4. If there are any changes to the existing selection, pressing the [Y/+] key the display will show “Save?” Then, press the [Y/+] key to save the change or press [N/] to go back to Step 2.

4.7.12 Changing the DAC Range

There are three different DAC (Digital-to-Analog Conversion) range values available in the ppbRAE: 2, 20, and 200 ppm. The maximum 2.5V DC analog signal output from the unit will represent the range value chosen (see for analog signal output connection).

1. “Change DAC Range?” is the twelfth sub-menu item in the Monitor Setup menu.
2. Press the [Y/+] key, the display shows the current DAC Range value: “DAC Range = 2000 ppb?”
3. Press the [Y/+] key to accept the currently displayed value. Press [N/] to scroll through the sub-menu for other range values. Press [MODE] to exit this sub-menu and return to the first sub-menu in Table 4-6.
4. If there is any change to the existing selection, pressing the [Y/+] key the display will show “Save?” Press the [Y/+] key to save the change or press the [N/] key to discard and return to the first sub-menu in Table 4-6.

4.8 Exit Programming Mode

1. To exit programming mode from the first tier menu level, press the [MODE] key once.
2. To exit programming mode from 2nd tier sub-menu, press the [MODE] key twice.
3. To return to programming mode, press and hold down both the [MODE] and [N/] keys for 3 seconds.

5 Computer Interface

Each ppbRAE is shipped with a software package, called ProRAE-Suite, and a serial computer interface cable.

This software package runs on any IBM compatible Personal Computer (PC) under Windows 95, Windows 98, Windows NT 4.0 and later environments. It allows the user to configure the ppbRAE through a user-friendly interface and send the configuration information from the PC to the ppbRAE monitor. Collected data can also be extracted from the ppbRAE to the PC in order to perform data analysis, report generation or record keeping. Installation and operation of this software package is described in the following sections.

5.1 Install ProRAE-Suite Software

The ProRAE-Suite software package is available on 3.5” setup diskettes. To install the ProRAE-Suite software, insert the first setup diskette into the “A” or “B” floppy disk drive. Click the Start button on the taskbar to display the start menu, then click Run from the start menu to display the Run dialog box. If the setup diskette is in disk drive A, type A:\Setup.exe in the Open field, as shown in Figure 5-1.

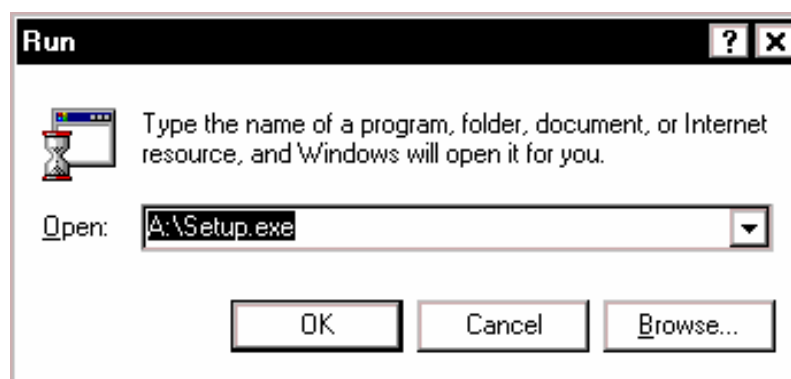

Figure 5-1. Run Dialog Box

Press the Enter key on the keyboard or click the OK button on the Run dialog box to start the setup process. If the user chooses the default settings in every step of the process, the ProRAE-Suite software will be installed under the default directory: C:\Program Files\RAE Systems Inc\ProRAE-Suite. After the software is installed successfully, a new menu item (ProRAE-Suite) is added to the Programs menu.

To start the ProRAE-Suite software, click the Start button on the taskbar to display the Start menu, click the Programs menu item to display the Programs submenu, then click the ProRAE-Suite menu item to display the ProRAE-Suite submenu. There are two submenu items under the ProRAE-Suite submenu: ProRAE-Suite and Readme, as shown in Figure 5-2. Click the ProRAE-Suite sub-menu item to start the ProRAE-Suite software.

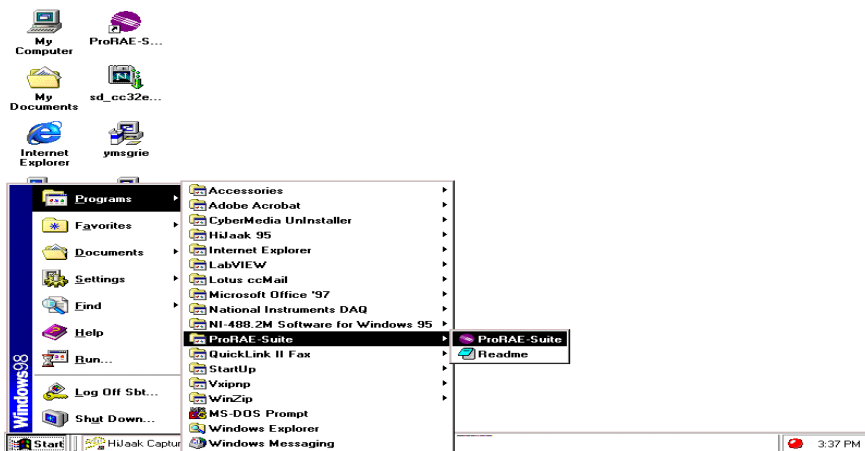

Figure 5-2. Start Menu

5.2 Connecting ppbRAE to the PC

The basic kit of the ppbRAE is supplied with a serial interface cable. Connect the DB-9 connector side of the cable to the serial port of the PC, and connect another side of the cable to the ppbRAE monitor.

Turn on the power to the ppbRAE monitor. Press the [MODE] key several times until the LCD shows “PC comm?” Press the [Y/+] key and the display shows “Pause monitor, OK?” Press [Y/+] key to confirm and the display shows “Comm...” to indicate that the ppbRAE monitor is ready and waiting for communication with the PC. During the communication session, the PC will directly control the ppbRAE monitor through the serial link. There is no need for users to press any keys on the ppbRAE monitor during the communication session.

If no data transfer has occurred within two minutes, the ppbRAE monitor will return to the instantaneous reading display.

Note: Do not mistakenly connect to the parallel port of the PC. The parallel port is usually a 25 pin female D connector on the back of the PC, the serial port is usually a 25 or 9 pin male D connector. If the serial port on the PC is a 25-pin connector, the user needs to use a 25 pin to 9-pin adapter in order to accept the serial cable.

5.3 Starting ProRAE-Suite Software

To start the ProRAE-Suite software, click the Start button on the taskbar to display the Start menu, click Programs ProRAE-Suite □ ProRAE-Suite sub-menu item to start the ProRAE-Suite software. Figure 5-3 shows the main window of the ProRAE-Suite software.

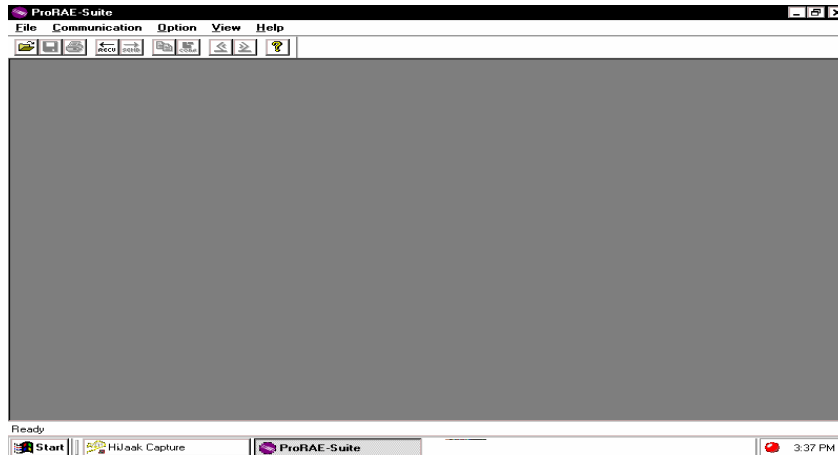

Figure 5-3. ProRAE-Suite Main Window

The functions of ProRAE-Suite software can be divided into three categories:

Configuration of data: The ProRAE-Suite software package has the ability to send and receive the configuration data from the ppbRAE monitor as well as edit the configuration data file.

Logging of data: Data logged from the ppbRAE monitor is received, displayed in multiple formats, exported to a tab delimited file to be read and worked with in conjunction with Microsoft Excel, etc.

Upgrading: Pro-RAE Suite also includes the ability to upgrade the datalog feature and firmware of the ppbRAE monitor and upgrade the firmware.

There is a tool bar beneath the menu bar. The frequently used functions are represented in this tool bar in the form of

small icons. For example, the Receive data function in the Communication sub-menu is represented as a small arrow with the letters "RECV." When the mouse cursor (a small arrow) is positioned near each icon in the tool bar, a short text will also appear at the bottom of the Window to describe the function of this icon.

This tool bar allows users to invoke a function conveniently by clicking on the icon without going through the sub-menus.

5.4 Setup Communication Port

It is necessary to setup the communication port on the ProRAE-Suite software so that the ppbRAE monitor can communicate with the PC correctly. Figure 5-4 shows the Setup Port dialog box. Choose the appropriate port according to the PC's serial port setup.

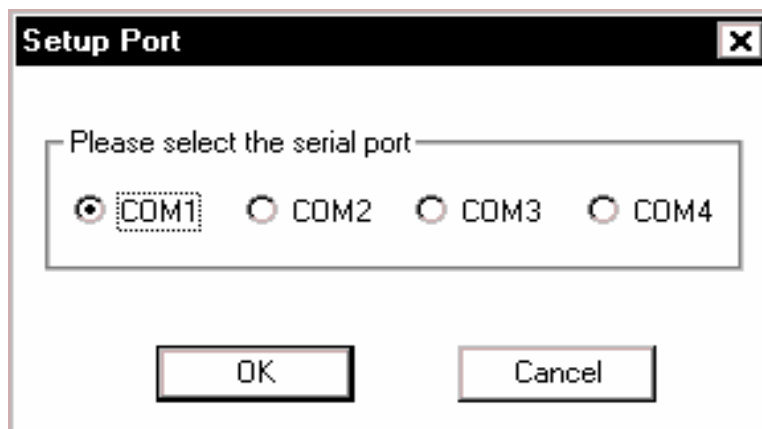

Figure 5-4. Setup Port Dialog Box

Note: In most PC's, there are two serial ports. Make sure that the serial port selected in the Setup Port dialog box matches the actual serial port connected to the ppbRAE monitor. The default serial port for ProRAE-Suite is COM1. If the incorrect serial port is selected, an error message of “error occurred during serial port initialization” will appear when a user tries to communicate between the PC and the ppbRAE monitor.

5.5 Processing Configuration Data

The ProRAE-Suite software allows the user to send configuration data to, receive configuration data from, and edit the configuration data from the ppbRAE monitor. The following sub-sections describe the details of each operation.

5.5.1 Editing the Configuration Data

There are two possible sources of configuration files: either saved on a computer or downloaded from the unit.

Load and review the monitor configuration. From the main menu of the ProRAE-Suite software, select the Receive Configuration... menu item from the Communication dropdown menu, then click OK if the unit is connected to the communication port and ready.

Load a saved configuration file. From the main menu, select Open from the File... dropdown menu, a dialog box appears. Select the “Files of type:” to Config Files[*.cfg], as shown in Figure 5-5.

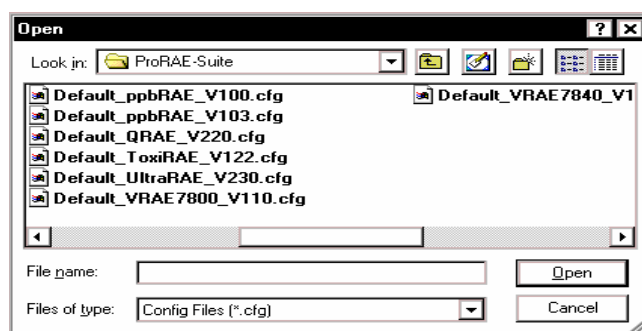

Figure 5-5. Open File Dialog Box

There should be one or more configuration files in the file list. Each configuration file has a file extension of “.CFG”. There is one generic ppbRAE configuration file supplied with the ProRAE-Suite software:

Default_ppbRAE_V####.CFG, where #### is the version number of the default configuration file. For example, Default_ppbRAE_V100.cfg means this file is for ppbRAE monitor and its version is V1.00.

Choose a configuration file by highlighting the file name and press the Enter key or click the Open button on the dialog box. Once the configuration file is open, the configuration data is displayed in the newly opened client window, as shown in Figure 5-6.

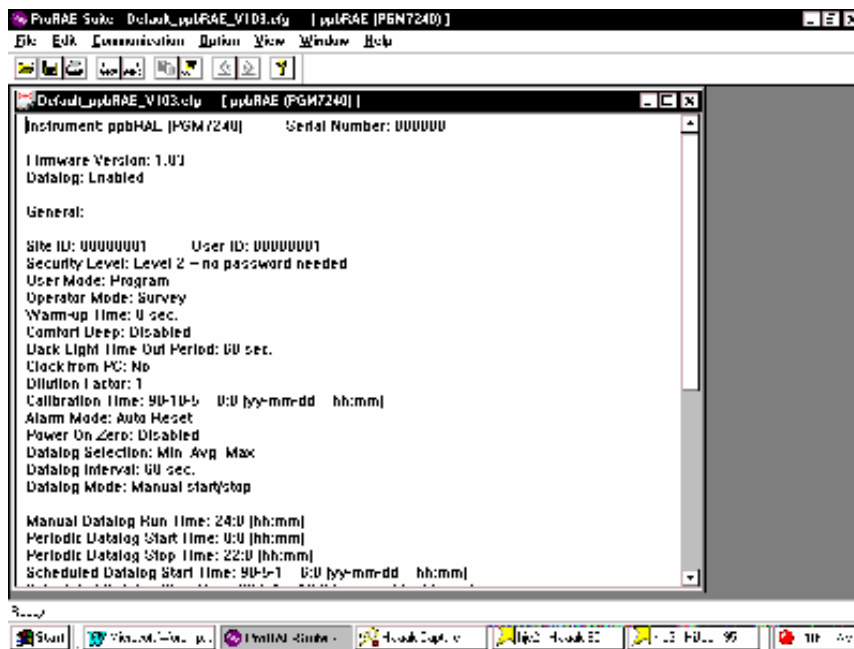

Figure 5-6. Displayed configuration data

To edit the opened configuration data file, click the Edit Configuration menu item or the Configuration toolbar button to open the Edit Configuration File dialog box, as shown in Figure 5-7. After completing the editing of the configuration settings, click the OK button to close the Edit Configuration File dialog box. The new values of the configuration settings will be reflected in the client window.

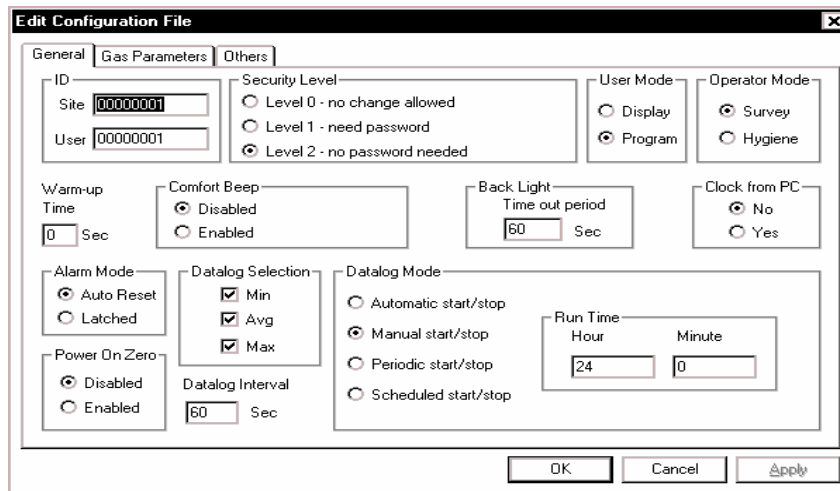

Figure 5-7. Edit Configuration File Dialog Box

General Tab Page

The General tab page, which is shown in Figure 5-7, allows the user to change the general settings of the configuration data. The following is the description of each field in the General tab page of the Edit Configuration File dialog:

ID: This section sets the identification that is used throughout the datalog process. Both editing fields, Site and User, can hold up to eight alphanumeric letters.

Security Level: There are three levels of security. Use security level to provide protection against unauthorized changes to the monitor settings in the programming mode.

Level 0 allows the user to enter the programming menu without password checking, but does not allow changes to alarm limits, real time clock, correction factor, or user and site information, etc. The user can still perform calibrations.

Level 1 is selected, a four-digit password is required to enter the programming menu.

Level 2 is selected, the programming menu may be entered without restriction. Any changes made in the programming menu can be saved.

Password: Entry to the programming menu requires the four-digit password to be entered if Level 1 is selected as the security level.

User mode: In the Display mode, the user can view several readings in the normal operation, but cannot enter the programming menu. In the Program mode, the user can enter the programming mode to calibrate the monitor or change various setups in the monitor.

Operator Mode: There are two operator modes the user can set: Hygiene and Survey. The Hygiene mode is a continuous measurement mode. The Survey mode is a manual start and stop measurement mode. See Chapter 2 for more details on the Hygiene and Survey modes.

Warm-up Time: This option allows the user to choose the warm-up time of the instrument, in seconds.

Comfort Beep: This option allows the user to specify a time interval in which the buzzer will beep once to remind the user that the monitor is on. If zero is entered for the time interval, then the comfort beep feature is disabled.

Back Light: This option allows the user to enter a time out period so that the back light will be turned off automatically after the time out period.

Clock from PC: This option allows the PC clock to be downloaded to the ppbRAE monitor so that the user does not need to manually set the clock in the ppbRAE monitor.

Alarm mode: This option allows the alarm to be either latched or auto-reset. Selecting auto-reset turns the alarms off automatically when the alarm situation no longer exists. The latched option keeps the alarms on even after the alarm situation clears; the alarm must be turned off manually by pressing the [Y/+] key to acknowledge the alarm situation.

Power On Zero: This option allows the monitor to perform a fresh air calibration automatically when the monitor is turned on. Care must be taken, when using this mode, to ensure that the monitor is in a fresh air environment and the unit has been warmed up when turned on.

Datalog Interval: The datalog interval is the rate at which datalog samples are recorded while the datalog is running. The units of the datalog interval are seconds. The datalog interval determines how often a new sample is calculated and stored to the datalog.

Datalog Selection: The user can choose one or more values for datalogging purposes. User can also choose to datalog the minimum, average, and maximum values, or any combination of the three values.

Datalog Mode: This may be set to either of four choices:

- With Automatic start/stop, the datalogging begins when the monitor is turned on and ends when it is turned off.
- With Manual start/stop, the datalog can begin by a series of key presses in the menu of normal operation. The maximum run time determines an automatic end to the datalog or it can be stopped manually.
- If Periodic start/stop (or daily) mode is chosen, the user must specify the start and stop hour and minute. The interval between start and stop is the period of time the monitor will datalog (at the “data logging period” rate).
- With Scheduled start/stop, all the entry boxes for year, month, day, hour and minute for both start and stop time must be entered to specify when the datalog is to occur.

Run Time: If the manual start/stop mode for datalogging is chosen, the user needs to specify a maximum run time. After the monitor has been on for the specified run time, datalogging will be turned off automatically.

Start Time and Stop Time: If scheduled start/stop mode is chosen for datalogging, all entry boxes must be completed for start and stop year, month, day, hour and minute. The monitor must already be turned on. Then once the start date/time is reached, the monitor will start datalogging. When the stop date/time is reached, the datalogging will stop automatically. With periodic start/stop mode, the hours and minutes are used for the datalog period to be run each day.

OK/Cancel: When the configuration changes are completed, click on the OK button to save the configuration and return to the client window, or click on the Cancel button to abort the configuration changes.

Gas Parameters Tab Page

In the Gas Parameters tab, located behind the general tab page, the user can change measurement units, current gas selections, cal memory selections, and the parameters of the current gas. The following is the description of each field in the Gas Parameters tab page of the Edit Configuration File dialog, see Figure 5-8.

Measurement Unit: This section allows the user to choose between parts per million (ppm), milligrams per cubic meter (mg/m³), parts per billion (ppb), and micrograms per cubic meter (ug/m³) as the standard unit of measurement.

Edit Configuration File

General Gas Parameters Others

Measurement Unit
 ppm mg/m3 ppb ug/m3

Current Gas Selection: Isobutylene Cal Memory Selection: Memory 0

Parameters of Current Gas

Alarm Levels (ppb)

STEL	TWA	Low	High
25000	10000	10000	25000

Calibration Span (ppb) 10000

Response Factors

10.6 eV Lamp	11.7 eV Lamp	9.8 eV Lamp
1.0	1.0	1.0

Figure 5-8. Gas Parameters Tab Page

Caution: The error message: “You just changed the measure unit from ‘ppm/ppb’ to ‘mg/m3 or ug/m3’, please update the Alarm Levels fields and the Calibration Span field!” will appear when converting between non-scalable units. The conversion is not done automatically.

Current Gas Selection: This option allows the user to choose the specific gas monitored. Click on the arrow at the right of the dialog box to scroll through the selection of gases offered.

Cal Memory Selection: There are eight memory possibilities, numbered “Memory 0” through “Memory 7,” that will store previous calibration settings.

Current Parameters Gas: The current STEL, TWA, Low, and High alarm levels are displayed in ppb units, as well as the calibration span. The correction factors of the three available lamps (10.6 eV, 11.7 eV or 9.8 eV) are also displayed.

Note: 11.7 eV lamps are not recommended for use with the ppbRAE even though the correction factor is available.

Others Tab Page

In the Others tab, the user can put in a power-on-customized name. The name will be displayed when the unit is powered on.

5.5.2 Sending Configuration Data to Unit

After the ProRAE-Suit software opens the configuration data file, the user can send the configuration settings to the ppbRAE monitor. To send the configuration settings to the instrument, click Communication Send Config menu item or click the Send toolbar icon (right arrow with “Send” letters), a message box will appear to remind the user to connect the instrument to the PC through the serial port. After making sure that the instrument is connected to the PC and ready for communication, click the OK button to start the data transfer.

After the configuration information is sent successfully, a message box will appear to indicate that the configuration sending process is completed. Click the OK button to close the message box.

If the communication is not successful, an error message indicating that there is no response from the instrument will appear. Check the cable to make sure that the connectors on both ends of the cable are securely seated in the sockets and the unit is set to be communication ready, and then try to send the configuration again. If the error message still appears after repeated attempts, call an authorized service center for help.

5.5.3 Saving Configuration Data

In order to save the configuration information for future use click File Save or the File Save As menu item to save the opened configuration data to a file. Once the configuration file is saved on disk, it can be opened at a later time for further modification or can be sent to the ppbRAE monitor.

5.5.4 Configuring All Settings

The user can use this function to update all the configuration settings (except the instrument ID, serial number and the datalog option) in the ppbRAE monitor. To configure all the settings in the instrument, click the Option Config All menu item, and a message box will appear to remind the user to connect the instrument to the PC through the serial port. After making sure that the instrument is connected to the PC, click the OK button. Another message box will appear to warn the user that this operation will erase all the current configuration settings in the monitor. If the user does not want this to happen, click the Cancel button, otherwise click the OK button to start the data transfer.

After the information is sent successfully, a message box will appear to indicate that the sending configuration process is completed. Click the OK button to close the message box.

Warning: The Config All option is mainly used to restore the ppbRAE monitor's default operational settings when the configuration of the unit is non-recoverable and the unit is malfunctioning. Because the default parameters are not normally fit to a specific unit, a user will need to re-calibrate, re-setup the lamp, pump, and LCD contrast threshold, etc. Use this function only if necessary.

5.6 Processing the Logged Data

ProRAE-Suite allows the user to retrieve the logged data from the ppbRAE monitor and display the data in many different formats. The user can also export the displayed text to a tab delimited text file so that Microsoft Excel can read it directly.

5.6.1 Receiving Data

To receive logged data from the ppbRAE monitor, click the Communication Receive Data menu item or click the Receive Data toolbar button (left arrow with “Recv” letters). A message box will appear to remind user to connect the instrument to the PC through the serial port. After making sure the instrument is connected to the PC, click the OK button to start the data transfer. After the data transfer is finished, a new client window is opened with the newly received logged data displayed. In order to save the logged data for future use, user can click File Save or the File Save As menu item to save the newly received logged data to a file.

5.6.2 View Logged Data in Text Mode

Once the user opens a data file or receives the logged data from the instrument, a data window appears.

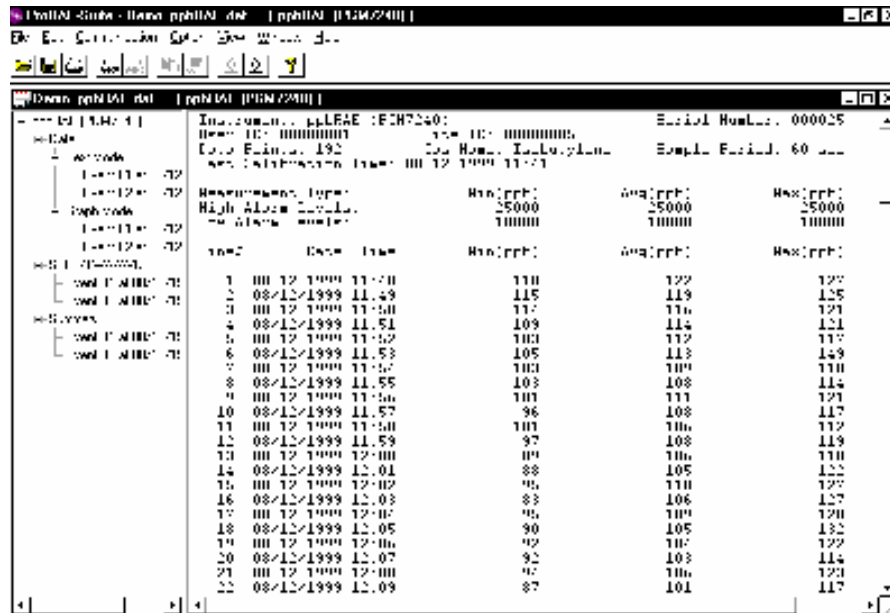

Figure 5-9. Displayed Logged Data

The data window is a two-pane client window. The left pane contains a tree view that lists all the display formats of each event, and the right pane displays the information according to the display format and the event the user selects in the left pane. To select any display format of any event, simply click the format item on the left pane. To view the next event or the previous event, click the Next Event (double right arrow) or the Previous Event (double left arrow) toolbar buttons. The user can also drag the splitter bar between the left pane and the right pane to the left or to the right to resize the pane as desired.

To view the data points of a specific event, click the item representing that event under the item Text Mode. For example, click the item Event #2 on the left pane, and the right pane displays the data points of event #2.

5.6.4 View the Summary Information

To view the summary information of any event, such as the peak and minimum values, click the event number item under the left tree item Summary (Figure 5-11)

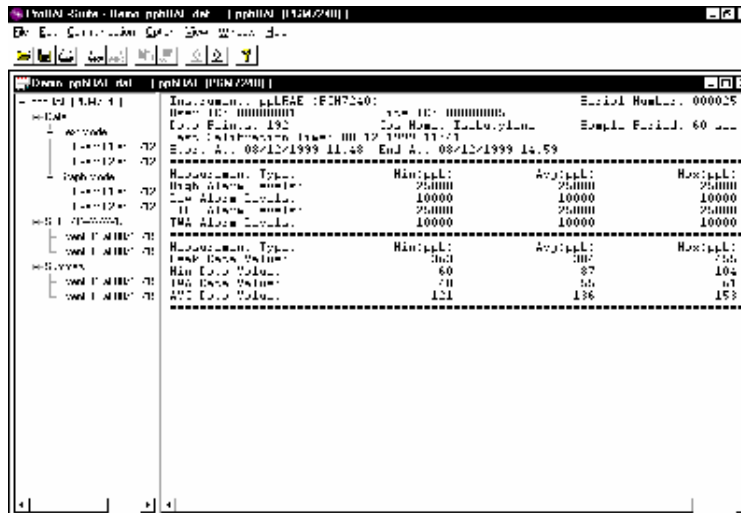

Figure 5-11. Logged Data Summary Information

5.6.5 View Logged Data in Graph Mode

To view the logged data of a specific event in graph mode, click the event item under the tree item Graph Mode in the left pane, and the right pane displays the graph of that event, as shown in Figure 5-12.

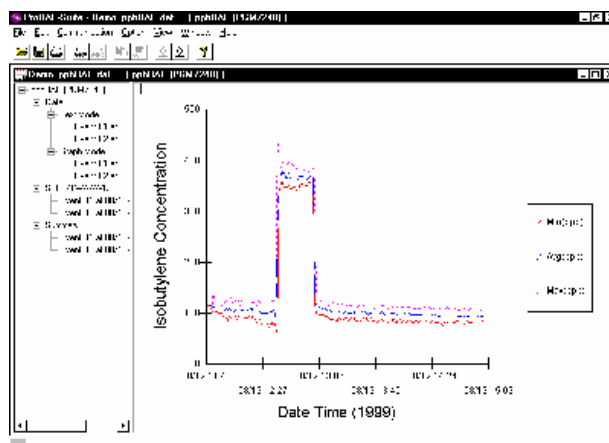

Figure 5-12. Graph of Logged Data

Select graph type: Choose the type of data in the Graph Type tab page of the Graph Settings dialog box. To display the Graph Settings dialog box, click anywhere within the right hand-side pane, then click the Option Graph Settings menu item to display the Graph Settings dialog box.

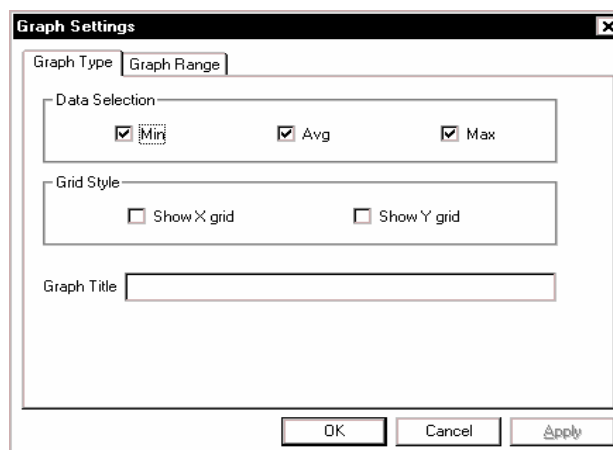

Figure 5-13. Graph Type Tab Page

Select graph range: Choose the value range on the x-axis and y-axis in the Graph Range tab page of the Graph Settings dialog box. To display the Graph Settings dialog box, click anywhere within the right-hand pane, then click Option Graph Settings menu item to display the Graph Settings dialog box. To bring up the Graph Range tab page, simply click the page header of the Graph Range tab page. Figure 5-14 shows the Graph Range tab page of the Graph Settings dialog box. Here, the user can choose the graph range on the x and y-axes.

The screenshot shows the 'Graph Settings' dialog box with the 'Graph Range' tab selected. The dialog is divided into two main sections: 'Y Axis (Data Value) Range Type' and 'X Axis (Data Time) Range Type'. In the Y-axis section, the 'Default' radio button is selected, and the 'Data Value Range (Y-axis)' group box contains 'Top Value' set to 100 and 'Bottom Value' set to 0. In the X-axis section, the 'Default' radio button is also selected, and the 'Start Time (X-axis)' group box contains Year: 1996, Month: 9, Day: 19, Hour: 8, and Minute: 0. The 'End Time (X-axis)' group box contains Year: 1996, Month: 9, Day: 19, Hour: 13, and Minute: 47. At the bottom of the dialog are 'OK', 'Cancel', and 'Apply' buttons.

Figure 5-14. Graph Range Tab Page

To choose the range of the y-axis, first click the User Defined radio button in the y-axis (Data Value) Range type group box, then the user can specify the top value and the bottom value in the Data Value Range (y-axis) group box.

If the user selects the Default radio button in the y-axis (Data Value) Range type group box, the ProRAE-Suite software will scale the range of y-axis automatically to cover the maximum data value inputted on the y-axis.

To choose the x-axis range, first click the User Defined radio button in the x-axis (Data Time) Range type group box, then specify the start time fields in the Start Time (x-axis) group box and the end time fields in the End Time (x-axis) group box. If the Default radio button is selected in the x-axis (Data Time) Range group box, ProRAE-Suite will scale the range of x-axis automatically to cover every data point on the x-axis.

5.6.6 Exporting Displayed Data to Text

The ProRAE-Suite software allows the user to export the displayed text to a tab delimited text file so that Microsoft Excel can read it directly. To export the text displayed in the right pane to a tab delimited text file, click the Option Export Text menu item, a Save As dialog box is displayed. Specify the file name in the File name field, then click the Save button.

5.6.7 Exporting Graphics to a File

The ProRAE-Suite software allows the user to export the displayed graph to a windows bitmap (.bmp) file or a windows metafile (.wmf) file. To export the displayed graph click clicking anywhere within the right-hand pane, then click the Option Export Graph menu item to display a Save As dialog box. Select the export graph file type (.bmp or .wmf) in the Save as type field, then specify the export file name in the File name field. Click the Save button to close the Save As dialog box. The newly created graph file contains the graph displayed in the right pane.

5.6.8 Printing Logged Data

After viewing the data results, the user may print the data to obtain a hard copy of the text or graphics. First, click anywhere within the right hand-side pane, then select the File Print menu item, or click the Print toolbar button (a printer) to print the graphic or text data.

A printer setup dialog box will appear before the printing starts so that the paper size, orientation, printer type, etc. can be configured correctly.

5.6.9 Installing Datalog Capability

To upgrade to datalogging capability, open the ProRAE-Suite software. Do not open any configuration file or data file, so the ProRAE-Suite software has no client window open, as shown in Figure 5-15.

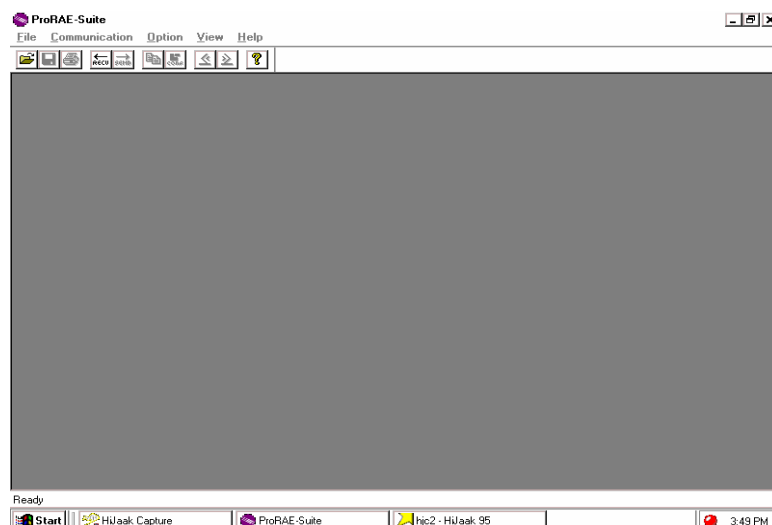

Figure 5-15. Main Window of Pro-RAE-Suite

Click the Option Enable Datalog menu item, and a message box will appear to remind the user to connect the instrument to the PC through the serial port. After making sure that the ppbRAE monitor is connected to the PC, click the OK button to start. After the ProRAE-Suite software has made successful contact to the instrument connected to the PC, a dialog box is displayed, as shown in Figure 5-16.

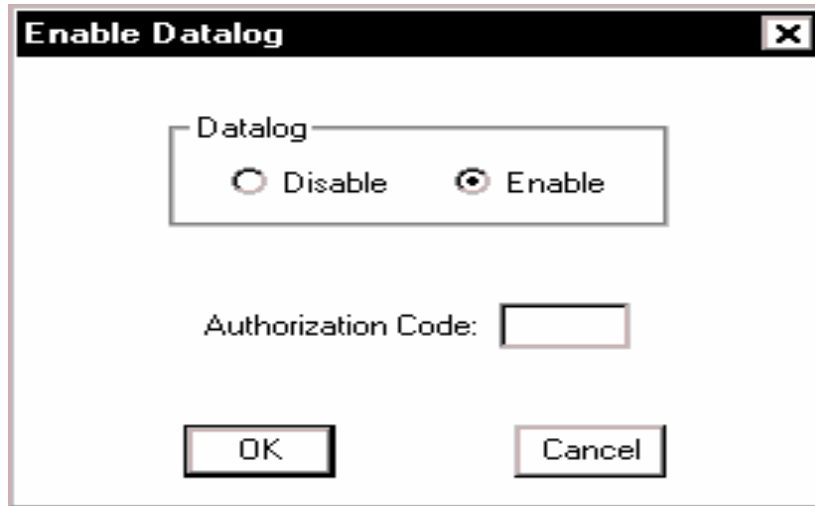

Figure 5-16. Enable Datalog Dialog Box

Figure 5-16 shows that the instrument's datalog feature is currently disabled. To enable the datalog option, click the Enable button, and type the three digit authorization code in the Authorization Code field, then click the OK button to close the dialog box. After the datalog option is changed, a message box will appear on the screen to indicate that the datalog option has successfully changed.

5.6 Upgrading the Firmware

To upgrade the firmware in the ppbRAE monitor, open the ProRAE-Suite software. Do not open any configuration file or data file, so the ProRAE-Suite software has no client window open, as shown in Figure 5-15. Click the Option Load Firmware menu item; a message box will appear to remind the user to connect the instrument to the PC through the serial port. After making sure that the instrument is connected to the PC, click the OK button. An Open dialog box is displayed, as shown in Figure 5-17. Select the firmware file (.a07) to be loaded into the instrument, and click the Open button to start the loading process. After the firmware loading is finished, a message box will appear on the screen to let the user know that the firmware has been successfully loaded into the instrument.

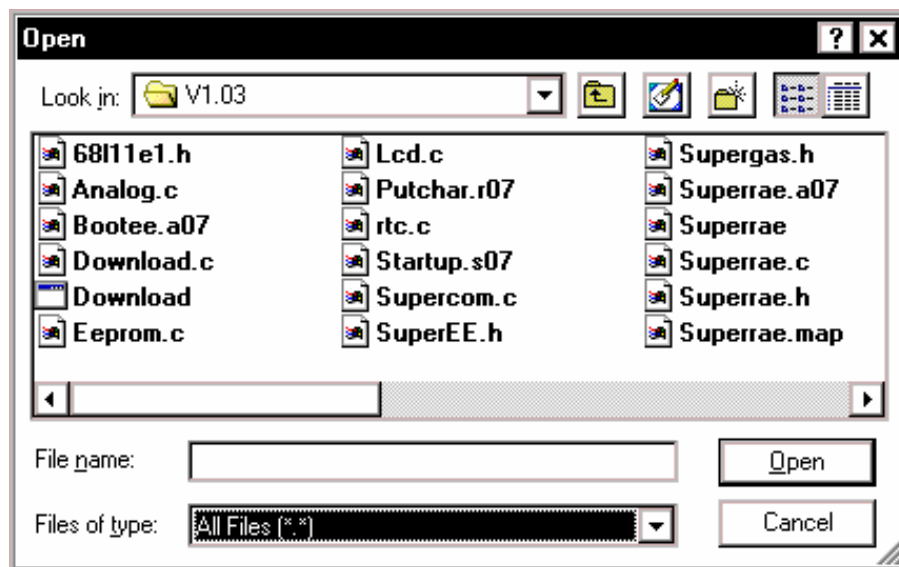

Figure 5-17. Open Firmware File Dialog Box

6 Theory of Operation

The ppbRAE monitor consists of a newly developed dual channel photo-ionization detector (PID) and an electrodeless discharge UV lamp as the high-energy photon source. Both channels of the detector are located in the ionization chamber. As organic vapors pass by the lamp, they are photo-ionized and the ejected electrons are detected as a current.

The first channel current primarily results from the ionized gases. The second channel current measures the ionized gases plus photoelectric emission of electrons from the metal surface, which is a function of the UV light intensity. The dual channel currents can thus be used to compensate the variation of the light intensity due to lamp contamination and degradation.

The dual channel structure allows the ppbRAE to determine the ionizable gas concentration accurately to a ppb (parts per billion) level without frequent calibrations. The PID sensor detects a broad range of organic vapors. The standard lamp for the ppbRAE is a 10.6 eV lamp, which yields the best resolution and sensitivity, and also has the longest lifetime. A lamp with high photon energies (e.g. 11.7 eV) measures a greater number of compounds, whereas low photon energies (e.g. 9.8 eV) are selective for easily ionizable compounds such as aromatics. However, at the current time, 11.7 eV lamps do not offer enough power to be used in the ppbRAE.

The PID sensor for the ppbRAE monitor is constructed as a small cavity in front of the UV lamp. A diaphragm pump inside the monitor continuously draws air through the sensor and then discharges it through a gas outlet port on the side of the monitor.

A single chip microcomputer is used to control the operation of the alarm buzzer, LED, pump and light sensor. It measures the sensor readings and calculates the gas concentrations based on calibration to known standard gases. The data are stored in non-volatile memory so that it can be sent to a PC for record keeping purposes. RS-232 transceivers provide a serial interface between the monitor and the serial port of a PC. An LCD display consisting of a single row of eight alpha/numeric characters is used to display the readings. The user interacts with the monitor through three keys on the front panel keypad.

A rechargeable NiMH, NiCd battery, or an alkaline battery pack powers the monitor.

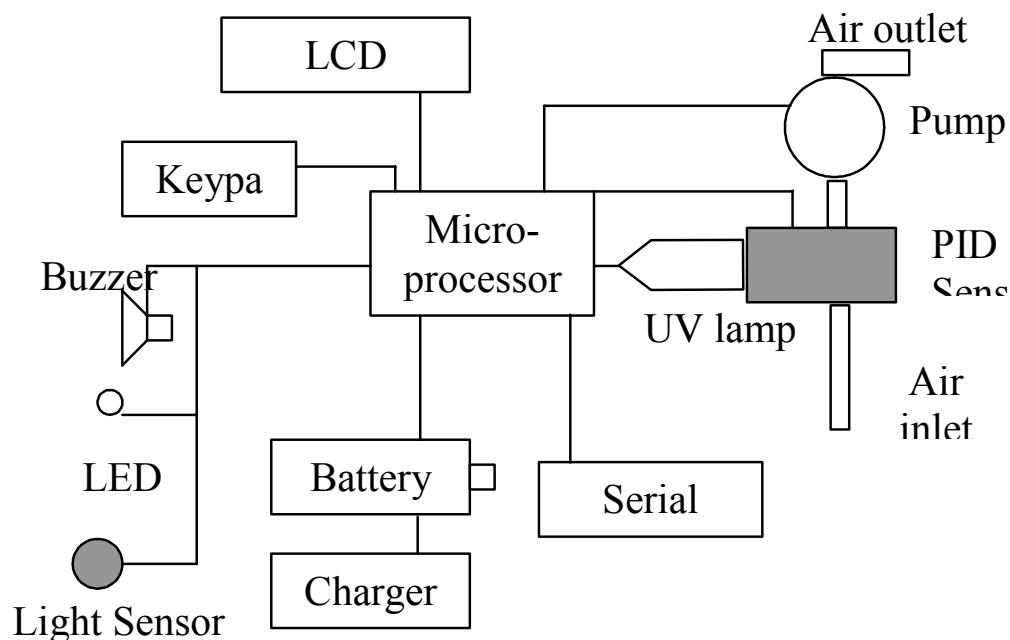

Figure 6-1. ppbRAE Schematic Diagram

Note: The printed circuit board of the monitor is connected to the battery pack even if the power is turned off. Therefore, it is very important to disconnect the battery pack before servicing or replacing any components inside the monitor. Severe damage to the printed circuit board or battery may occur if the battery pack is not disconnected before servicing the unit.

7 Maintenance

The major maintenance items of the ppbRAE are:

- Battery pack
- Sensor module
- PID lamp
- Sampling pump
- Inlet connectors and filters

Note: Maintenance should be performed by qualified personnel only.

7.1 Battery Charging & Replacement

When the display shows a flashing message “Bat,” the battery requires recharging (see Section 3.1 for Battery charging). It is recommended to recharge the ppbRAE monitor upon returning from fieldwork. A fully charged battery runs the monitor for 10 hours continuously. The charging time is less than 10 hours for a fully discharged battery. A built-in micro-controller prevents over-charging. The battery may be replaced in the field (in an area known to be non-hazardous) if required.

WARNING:

To reduce the risk of ignition of hazardous atmospheres, recharge battery only in an area known to be non-hazardous. Remove and replace the battery only in an area known to be non-hazardous.

Replacing the Battery Pack

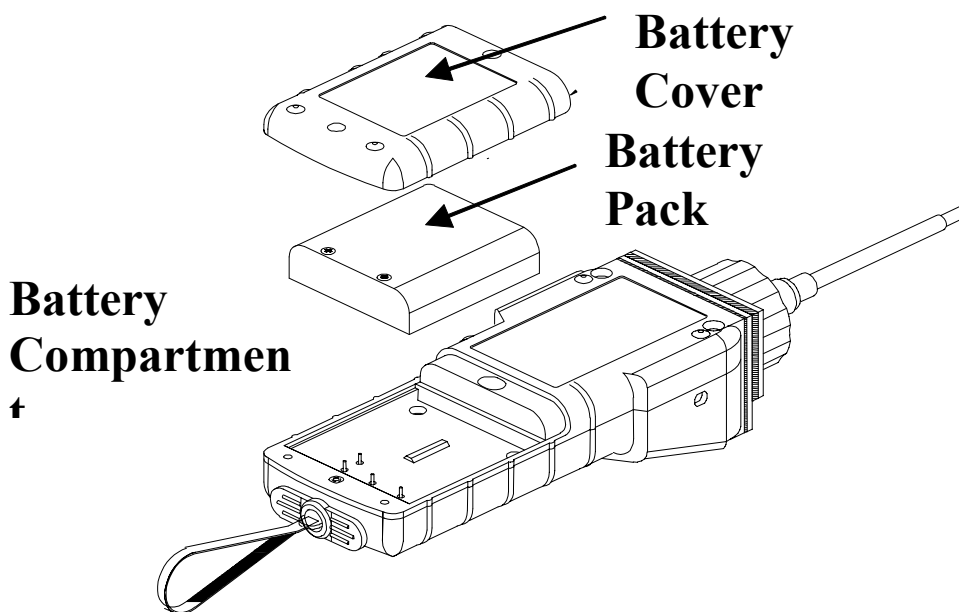

Figure 7-1. Battery Replacement

1. Turn off the power to the ppbRAE.
2. Unscrew the two battery compartment screws, located on the bottom of the monitor, and remove the cover.
3. Remove the battery pack from the battery compartment.
4. Place a fully charged spare battery pack inside the battery compartment. Make sure the battery pack is oriented properly inside the compartment.
5. Close the battery cover and tighten the two screws.

Replacing the Alkaline Battery Adapter

Insert four fresh AA size alkaline batteries into the alkaline battery holder. Make sure that the polarity of the batteries is correct. Follow the above procedures to replace the battery holder.

Note: The internal charging circuit is designed to prevent charging to alkaline batteries.

7.2 PID Sensor & Lamp Cleaning/Replacement

The sensor module is made of several components and is attached to the lamp-housing unit as shown in Figure 7-2.

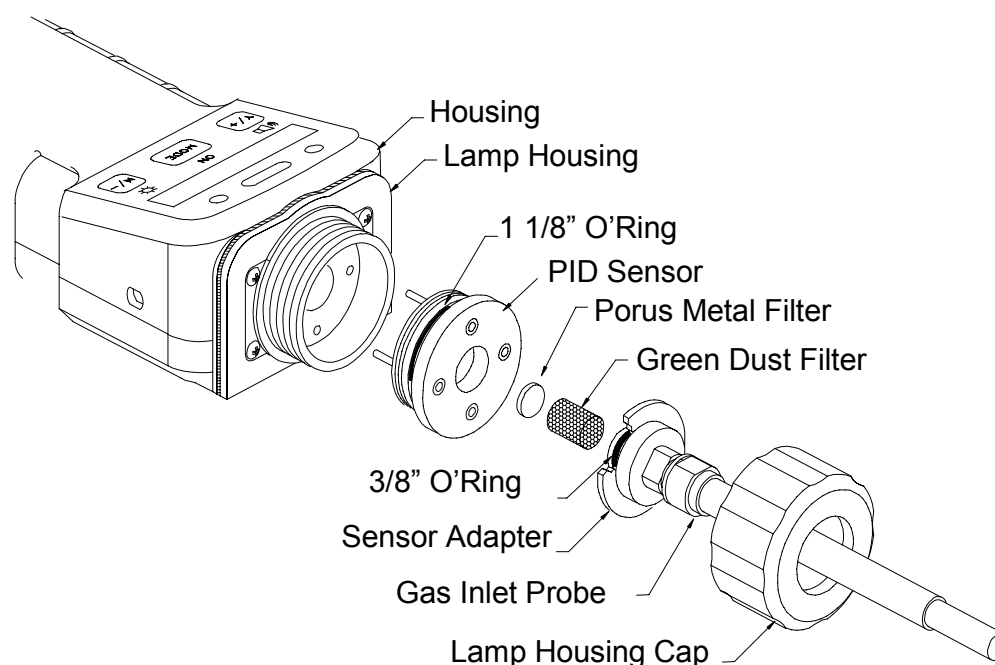

Figure 7-2. Probe and Sensor Components

Note: The cleaning procedure is not normally necessary. Clean the PID sensor module, the lamp and the lamp housing only when one of the following happens:

1. The reading is inaccurate even after calibration.
2. The reading is very sensitive to the moisture in the air.
3. A chemical liquid has been sucked into the unit and caused damage.

Use of the water trap filter will help to prevent contamination and accidents. To access the sensor components and lamp: gently unscrew the lamp-housing cap, remove the sensor adapter with the gas inlet probe and the metal filter altogether. Then hold the PID sensor and

pull straight out gently. A slight rocking motion helps ease out the sensor. If the lamp does not turn on, the monitor will display an error message (Lamp) to indicate replacement of the lamp may be required.

To clean the PID sensor

Place the entire PID sensor module into GC grade methanol. It is highly recommended that an ultrasound bath be used to clean the sensor for at least 15 minutes. Then dry the sensor thoroughly. Never touch the electrodes of the sensor.

To clean lamp housing or change the lamp

1. If the lamp is operational, clean the lamp window surface and the lamp housing by wiping it with GC grade methanol using a cotton swab. Rub in a circular motion at moderate pressure. After cleaning, hold the lamp up to light at an angle to detect any remaining film. Repeat the process until the lamp window is clean. Never use water solutions to clean the lamp. Dry the lamp and the lamp housing thoroughly after cleaning.

CAUTION:

Never touch the window surface with fingers or anything that may leave a film. Never use acetone or aqueous solutions, especially on 11.7 eV lamps.

2. If the lamp does not turn on, remove the UV lamp from the lamp housing. Insert a new lamp, avoiding contact with the flat window surface.
3. Reinstall the PID sensor module.
4. Tighten the Lamp Housing Cap.
5. If the lamp type has been changed, adjust the lamp type setting in the programming mode (Section 4.7.8).

7.3 Sampling Pump

When approaching the end of the specified lifetime of the pump, it will consume higher amounts of energy and reduce its sample draw capability significantly. When this occurs, it is necessary to replace or rebuild the pump.

When checking the pump flow, make sure that the inlet connector is tight and the inlet tubing is in good condition. Connect a flow meter to the gas inlet probe. The flow rate should be above 400 cc/min when there is no air leakage.

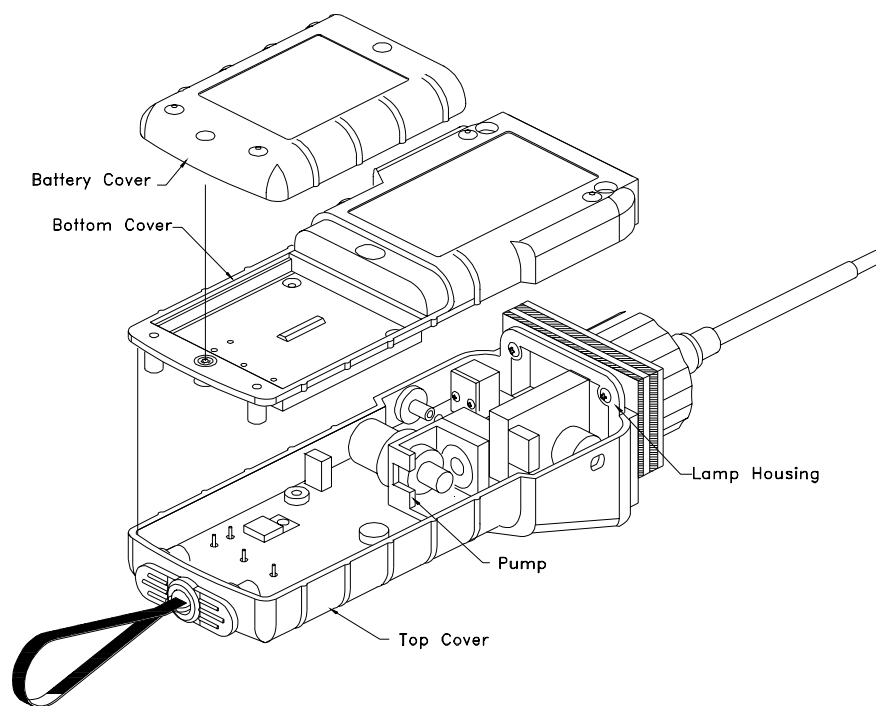

Figure 7-3. Sampling Pump Location

Pump Replacement

1. Turn off the ppbRAE power.
2. Open the battery cover, remove the battery pack, and carefully unscrew the six screws to open the bottom cover.
3. Unplug the pump from the PCB. Unscrew the two screws that hold the pump assembly to the PCB. Disconnect the Tygon tubing that connects the pump to the gas inlet port and gas outlet port.
4. Insert a new pump assembly. Connect the Tygon tubing to the gas inlet port. Plug the pump connector back into the PCB and screw down the pump assembly to the board.
5. Replace the bottom cover and tighten the six screws. Reconnect the battery pack. Replace the battery pack and its cover.

7.4 Turning on the UV Lamp

The UV lamp is made of a glass envelope and a UV window on one end of the envelope. The inside of the lamp is filled with low-pressure gases. To turn on the lamp, a high voltage electric field is applied from the outside of the glass envelope. The molecules inside the lamp are ionized and produce a glow discharge to generate the UV light.

If the UV lamp has not been used for a long period of time (>1 month), it may become slightly harder to turn on. If such a condition occurs, an error message “Lamp” will appear in the monitor display during the power on sequence. This phenomenon is more significant in 0.25” UV lamps used in ToxiRAE and MultiRAE Plus products, because of the relatively small lamp size.

To solve this problem, simply turn the monitor on and off a few times and the lamp should turn on. After the UV lamp is turned on for the first time, it should be easier to turn on the UV lamp the next time.

The ppbRAE has a built-in sensing mechanism to monitor the status of the UV lamp. If the UV lamp is not on, the error message “Lamp” will be displayed. If the lamp error message persists, then it is necessary to further diagnose the problem.

It is possible that the UV lamp is actually on when the lamp error message appears. This is because with old UV lamps the internal threshold level to detect lamp failure may have been shifted enough to cause a false alarm. To eliminate such a possibility, simply check to see that the UV lamp is actually on. This can be done easily by removing the sensor cap and observe the glow of the UV lamp in a dark area. The customer can also feed the monitor with calibration gas and observe if the sensor reading changes. If the reading changes significantly with the gas, the UV lamp is actually on. If the UV lamp is on while the error message persist, then it is necessary to adjust the lamp threshold. Please refer to “2) Adjust Lamp Failure Threshold” in Chapter 8 on adjusting the threshold level for the UV lamp.

One of the most common failure mechanisms for the UV lamp is the development of a leak along the seal of the glass envelope. When such a condition occurs, the lamp will become very hard or impossible to turn on. Therefore, after going through the above diagnostic procedures, if the UV lamp still cannot be turned on, it is most likely that the UV lamp must be replaced.

8 Troubleshooting

To aid the user in diagnosing the monitor, the monitor has a special diagnostic mode that can display critical, low level parameters. Section 8.1 describes the operation of the diagnostic mode. Section 8.2 summarizes the frequently encountered problems and suggested solutions. By turning on the ppbRAE monitor in diagnostic mode and using the troubleshooting table in Section 8.2, the user can usually correct the problem without having to return the monitor for repair.

WARNING:

This function should be used by qualified personnel only! The diagnostic mode allows the user to set several low-level parameters that are very critical to the operation of the monitor. Extra care should be taken when setting these low-level parameters. If the user is not familiar with these parameters and sets them incorrectly, it may cause the monitor to shut down or malfunction.

8.1 Special Diagnostic Mode

To turn on the monitor to the special diagnostic mode, push and hold the [Y/+] key, and then push and hold the [MODE] key for at least two seconds when the monitor is off. After the required delay, release both keys, the monitor will go through the start-up sequence and display a “Diagnostic mode” message. At the end of the special mode start-up, the display will show the raw counts of sensor channel 1A. These numbers are raw sensor readings without calibration.

In Diagnostic Mode the pump and lamp are normally on, and the user may enter Programming Mode and calibrate the instrument as usual by holding the [MODE] and [N/-] keys down simultaneously for 3 seconds. Once the monitor is started up in Diagnostic Mode, the user can switch between Diagnostic Mode and normal operating mode by pressing and holding down the [MODE] and [Y/+] keys simultaneously for 2 seconds.

Critical parameters of the monitor available in Diagnostic Mode are shown below. They can be reached by pressing the [MODE] key repeatedly until the desired parameters are displayed.

Table 8-1. Diagnostic Mode Menu

Key Action	Parameter	Display
	Raw Reading	1A (+ = 1X) 1B (+ = 1X)
[MODE]	Raw Reading	10A (+ = 10X) 10B (+ = 10X)
[Y/+]	Raw Reading	100A (+ = 100X) 100B (+ = 100X)
[MODE]	Lamp Current	Lamp = 103
[MODE]	Lamp Fail Level	Fail = 75 (+/-)
[MODE]	Lamp Drive*	Ldrv = 200 (+/-)# *
[MODE]	Battery Type	Ni-Cd/MH /Alkaline
[MODE]	LCD Contrast	Contrast (+/-)
[MODE]	Battery Duration	Battery Duration: XX:XX
[MODE]	Pump Current	Pump 7/ 7
[MODE]	Pump Stall Level	Stall 10 (+/-)
[MODE]	Pump Motor drive	Mdrv = 200 (+/-)*
[MODE]	DAC Output Count	DAC = 2048 (+/-)
[MODE]	Alarm Test	Alarm (on/off)?
[MODE]	Ambient Light Level	Lite = 237
[MODE]	Backlight Trip Level	Trip = 100 (+/-)
[MODE]	PC Comm	PC Comm?

* Normally this setting should not be changed.

The lamp drive is 200 for 10.6 eV lamp and 220 for others.

Below is a brief description of the diagnostic displays:

1. Raw Sensor Readings

The raw sensor readings provide a quick diagnosis on the response and the sensitivity of the sensor. When zero gas (fresh clean air) is applied to the monitor, the raw sensor readings typically should be between 100 and 200 for 1A and 1B, 100 and 400 for 10A and 10B, and 300 and 3000 for 100A and 100B. If the raw reading is outside this range when zero gas is applied, the sensor or the lamp housing may be dirty or the electronics may be defective.

When a specific gas is applied to the monitor, the raw reading should increase. If the reading does not change when the gas is applied, then the sensor or lamp may be defective.

2. Adjusting the Lamp Failure Threshold

This display can be used to calibrate the PID lamp failure threshold. If the lamp appears to be good but in normal operation, a lamp failure message (i.e. "Lamp") is displayed, the lamp failure level may be set too high. This level can be adjusted by using the following steps:

- a. Turn the monitor off. Remove the UV lamp from the PID sensor (see Section 7.2).
- b. Turn the monitor on in the special diagnostic mode ([Y/+] & [MODE]).
- c. Press the [MODE] key until "Lamp xxx" is displayed, write down this number. The reading "xxx" is the lamp's current reading.
- d. Press the [MODE] key one more time, "Fail yyy" is now displayed. The value "yyy" is the threshold

level that determines lamp failure. Anything below this level is considered a failure.

- e. Push the [Y/+] or [N/] key to increase or decrease the threshold value “yyy” until it is about 10-15 counts above the “xxx” value. This will optimally set the lamp failure threshold. Press the [MODE] key to exit this display. If the threshold value has changed, a message “Save?” will appear. Press [Y/+] to confirm the change, [N/] or [MODE] key to abandon the changes.
- f. Turn the monitor off and replace the lamp.
- g. To verify the above adjustment, turn the monitor back on in Diagnostic Mode and press the [MODE] key until “Lamp xxx” is displayed. Press the [MODE] key once more so that “Fail yyy +/-” is displayed. The lamp’s current reading “xxx” should be higher than the threshold value “yyy” by at least 10-15 counts. If not, the lamp may be defective or very weak.

In most cases lamp failure threshold adjust is not required, in which case the user should press the [MODE] key to exit this display.

3. Lamp Drive

For the 10.6eV lamp, use 200. For the 9.8eV and 11.7eV lamps, use 220 as the lamp drive value. Note that the 11.7 eV lamp is not recommended and both 9.8 and 11.7 will not meet the same sensitivity specifications as the 10.6 eV lamp.

4. Battery Type

The ppbRAE can be powered by either a rechargeable nominal 4.8V NiMH/NiCd battery pack or an alkaline battery holder. This display shows the type of battery currently installed in the monitor. The charger cable must be unplugged for a correct battery type display.

5. Adjusting the LCD Contrast

This display allows the user to adjust the LCD contrast. Press [Y/+] to increase the contrast and [N/] key to decrease the contrast. The bar graph shows the current LCD contrast setting. If the display appears blank or very faint, press the [Y/+] key several times to increase the contrast or darken the display.

6. Battery Duration

This display shows the run time of the last time the unit powered itself off due to a low battery or was turned off by the user. It is useful for battery life testing.

7. Adjusting the Pump Stall Threshold

This display can be used to calibrate the pump stall threshold. If the gas inlet is blocked but the pump does not shut down, or the pump shuts down too easily with a slight blockage, the pump stall threshold value may be set too high or too low. Use the following steps to adjust the pump stall threshold.

- a. In diagnostic mode, press the [MODE] key until “Pump xxx/yyy” is displayed. This is the maximum and average pump current under normal conditions.
- b. Block the gas inlet and watch the pump current reading increase. Write down the blocked reading. If the pump current reading does not increase significantly (i.e. more than ten counts), then there

may be a leak in the gas inlet or the pump is weak or defective. Press [MODE] one more time, and the display should show the message “Stall yyy”

- c. Use the [Y/+] or [N/-] key to increase or decrease the stall value until it is the average of the maximum block count and the maximum idle count. Press the [MODE] key to exit this display. If the threshold value is changed, a message “Save?” will appear. Press [Y/+] to confirm the change, [N/-] or [MODE] key to abandon the changes.

8. Motor Drive

This display allows the user to adjust the pump drive. Normally, the user should not adjust this parameter.

9. DAC Output Counts

The menu allows the user to check the DAC analog output using the [Y/+] and [N/] keys. The remote alarm output signal on the serial interface cable is deselected and the analog output signal is selected in its place. This signal has a range of 0 to 2.5V in 4096 steps. The initial default output is 2048, or 1.25V. See Figure 8-1 for signal pin-out. The user can attach a voltmeter to check the analog voltage output.

10. Alarm Test

This menu is used to test the monitor’s alarm generators, including four bright LED’s, the loud buzzer, and the vibrator output signal (remote alarm). The message “Alarm” is first displayed followed by “On?” If the [Y/+] key is pressed at this point, the alarms will turn on and the message “Off?” will appear. Press the [Y/+] key again to turn the alarms off. Check external alarm signal at connector.

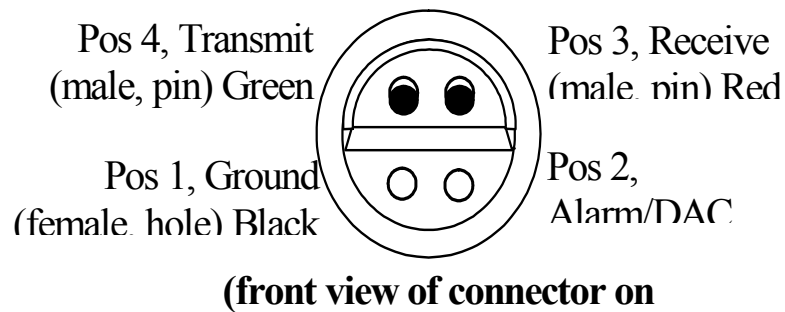

Figure 8-1. Communication/Alarm Connector

11. Adjusting the Back Light Threshold

This display can be used to calibrate the LCD back light on/off threshold. Use the following steps to adjust the back light threshold.

- a. The “Lite = xxx” message displays the present ambient light level incident on the face of the monitor. In a brightly-lit room, the light reading should be above 130.
- b. The user can shade the light sensor, which is located at the upper left corner of the monitor, with their hand and watch the light sensor reading. The light reading should drop to less than 100. Press the [MODE] key one more time, the display should show the message “Trip = 100”.
- c. Use the [Y/+] or [N/-] key to increase or decrease the trip value until it is 100. Press [MODE] to exit this display. If the threshold value is changed, a message “Save?” will appear. Press [Y/+] to confirm the change, [N/-] or [MODE] to abandon the changes.

Table 8-2. Troubleshooting Guide

Problem	Possible Reasons & Solutions
Cannot turn on after charging the battery	<p>Reasons: Discharged battery, defective battery, or microcomputer hang-up. Solutions: Charge or replace the battery. Disconnect, then connect the battery to reset the computer. No LED or LCD back light</p> <p>Reasons: Trigger level too low, in manual, defective LED or LCD back light.</p> <p>Solutions: Adjust the trigger level. Verify that the back light can be turned on in user mode. Call an authorized service center.</p>
Lost password	<p>Solutions: Use the default configuration to reset the password from computer. Warning: If the default configuration is loaded, all the parameters needed for setup. Including: pump, lamp and LCD contrast threshold. Enter the serial number and re-calibrate.</p>
Reading abnormally high	<p>Reasons: Dirty sensor module. Dirty water trap filter. Excessive moisture and water condensation.</p> <p>Solutions: Clean the sensor module and lamp housing. Replace water trap filter. Blow dry the sensor module.</p>

Continued

TROUBLESHOOTING

Buzzer inoperative	<p>Reasons: Bad buzzer</p> <p>Solutions: Call an authorized service center.</p>
Inlet flow too low	<p>Reasons: Pump diaphragm damaged or has debris. Flow path leaks.</p> <p>Solutions: Check flow path for leaks; sensor module O-ring, tube connections, Teflon tube compression fitting. Replace pump or diaphragm.</p>
“Lamp” message during operation	<p>Reasons: Lamp drive circuit. Lamp threshold set too high. Weak or defective PID lamp.</p> <p>Solutions: Check and reset lamp threshold. Replace the UV lamp.</p>
Full scale measurement in humid environment	<p>Reasons: Dirty or wet sensor</p> <p>Solutions: Clean and dry the sensor and lamp housing. Use water trap filter.</p>
Reading abnormally low	<p>Reasons: Incorrect calibration. Low sensitivity to the specific gas. Weak or dirty lamp. Air leakage.</p> <p>Solutions: Calibrate the monitor. Replace the sensor. Clean the lamp. Check for air leakage.</p>
Reading an abnormal background value	<p>Reasons: There is actually a small background gas level sensor zero drift.</p> <p>Solutions: Do a zero air calibration</p>

Continued

TROUBLESHOOTING

<p>Reading jumping around randomly</p>	<p>Reasons: Incorrect calibration gas value. Low sensitivity to cal gas. Weak or dirty lamp. Air leakage. Solutions: Calibrate the sensor. Use different a cal gas. Clean or replace the lamp. Check for air leakage.</p>
<p>Cannot turn off the monitor or there are corrupted characters in the LCD display</p>	<p>Reasons: Microprocessor hang-up. Solutions: Disconnect and re-connect the battery to reset computer. Call an authorized service center.</p>
<p>“Bat” message during operation</p>	<p>Reasons: Discharged battery. Solutions: Recharge battery.</p>
<p>Excessive pump noise or no inlet air suction</p>	<p>Reasons: Blocked inlet path. Defective pump. Solutions: Check inlet connection. Check pump.</p>
<p>Calibration error message</p>	<p>Reasons: No standard gas input. W, weak PID lamp. U, unit zeroed with gas present. Solutions: Make sure standard gas flows into monitor. Zero sensor & recalibrate, replace lamp</p>

QUICK REFERENCE GUIDE: Programming Mode

Calibrate/select Gas?

- Fresh air cal?
- Span cal?
- Select cal memory?
- Change span value?
- Modify cal memory?
- Change correction factor?

Change alarm limits?

- High limit?
- Low limit?
- STEL limit?
- TWA limit?

View/change datalog?

- View Data?
- Clear Data?
- Change Data Period?
- Change Average Type?

Change monitor setup?

- Change Op mode?
- Change Site ID?
- Change User ID?
- Change Alarm Mode?
- Change User Mode?
- Change Date?
- Change Time?
- Change Lamp?
- Change Unit?
- Change Pump Speed?
- Change Output?
- Change DAC Range?

APPENDIX B

EXPENDABLE AND REPLACEMENT PART LIST

The replacement part number of the standard expendables and common repair parts are listed in the table below:

Part Number	Part Description
000-5001-000	ProRAE-Suite software
002-3008-000	Organic vapor zero kit
002-3011-000	Regulator with adapter
008-3003-000	Computer interface cable
011-2011-000	Lamp housing shield
011-2027-000	Lamp housing cap
011-3006-000	Filter and O-ring
012-3009-000	Air outlet adapter
012-3051-000	NiMH battery pack
012-3052-000	Battery adapter
017-3012-000	Inlet probe
025-3009-000	Hard transport case
025-3042-000	Rubber boot
025-4001-000	ppbRAE manual
050-0000-001	½", 10.6 eV electrodeless UV lamp
050-0001-000	½", 11.7 eV electrodeless UV lamp
050-0020-000	½", 9.8 eV electrodeless UV lamp
081-0004-000	Charcoal filter, 6 pack
081-0008-000	Tool kit
300-0012-170	Pump
411-0018-037	Tygon tubing, 1/8" diameter inside
430-0014-001	O-ring, ½" diameter inside
430-0025-001	O-ring, 3/8" diameter inside
500-0036-000	Batter charger, 110VAC, 12VDC
600-0069-000	10 ppm isobutylene

Main Office

RAE Systems Inc.
1339 Moffett Park Drive
Sunnyvale, California 94089

Main Contact Numbers

Telephone

408.752.0723

Fax

408.752.0724

Toll Free Numbers

Instrument Sales

877.723.2878

Technical Service

408.585.3540

E-mail

RaeSales@raesystems.com

Tech@raesystems.com

Website

www.raesystems.com
